



GANESH INSTITUTE OF ENGINEERING AND TECHNOLOGY
Bhubaneswar

Switch Gear and Protective Devices (Th-02)

(As per the 2020-21 syllabus of the SCTE&VT,
Bhubaneswar, Odisha)



Sixth Semester

Electrical Engineering.

Prepared by: Koushik Roy

INTRODUCTION TO SWITCH GEAR

Switch gear: The apparatus used for switching, controlling and protecting the electrical circuits and equipment is known as switch gear.

Essential features of switch gear: The essential features of switch gear are:

- **Complete reliability:** When fault occurs on any part of the power system, the switch gear must be reliable to operate to isolate the fault section from the remainder of the circuit.
- **Absolute certain discrimination:** When a fault occurs on any section of the power system, the switch gear must be able to discriminate between the fault section and the healthy section.
- **Quick operation:** When a fault occurs on any part of the power system, the switch gear must operate quickly so that no damage is done to the generating and other equipments by the short circuit current.
- **Provision for manual control:** It must have a provision for manual control.
- **Provision for instrument:** It is essential that for a switch gear to measure current, power, voltage. So an ammeter, voltmeter, wattmeter etc. are required.

Switch gear equipment:

- **Switch:** A switch is a device which is used to open or close an electrical circuit easily.
- **Air break switch:** It is an air switch and is designed to open a circuit under load.
- **Isolator or disconnecting switch:** It is a knife shape switch and is designed to open under no load.
- **Oil switches:** In oil switches the contacts of switches are open under oil (usually transformer oil).
- **Fuses:** A fuse is a short piece of wire or thin strip which melts when excessive current flows through it for sufficient time.
- **Circuit breaker:** A circuit breaker is an equipment which can open or close a circuit under all conditions i.e. no load, full load and fault conditions.
- **Relay:** A relay is a device which detects the fault and supplies information to the breaker for circuit interruption.

Bus bar arrangements: Bus bars are copper rods or thin walled tubes and operate at constant voltage.

- Single bus bar system.
- Single bus bar system with sectionalisation
- Duplicate bus-bar system

Single bus bar system:

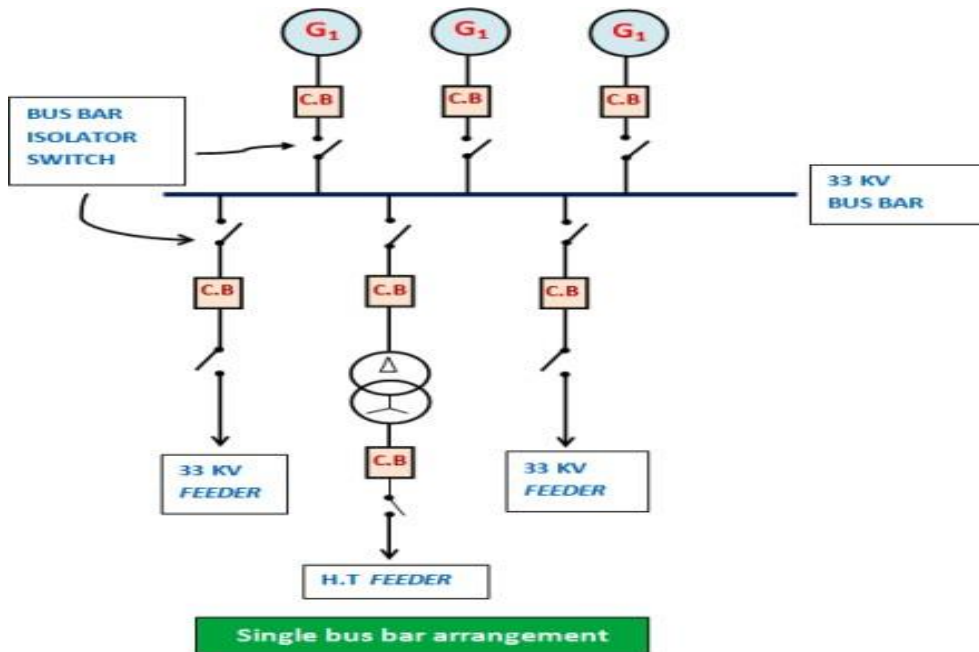

- Here only one bus is used.
- It is simple in design.
- It has low initial cost ,less maintenance and simple operation.
- If fault occurs on bus bar it self,there is complete interruption of supply.
- In this arrangement the bus bar cannot be cleaned,repared or tested.
- It is employed in small outdoor system.

Single bus-bar system with sectionalisation:

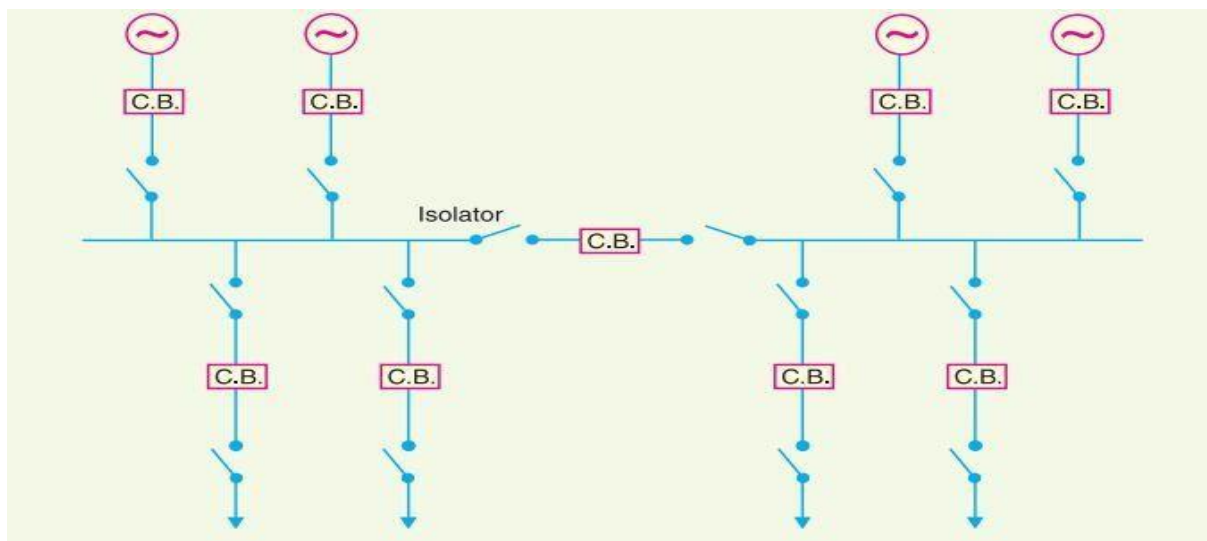

- It is employed in large generating station.
- Here the bus-bar divided into two sections connected by a circuit breaker and isolators.
- If fault occurs on any section of the bus-bar ,that section can be isolated without affecting the supply to other section.
- In this system bus-bar maintenance and repair is simple.

Duplicate bus-bar system:

BUS-BAR ARRANGEMENTS

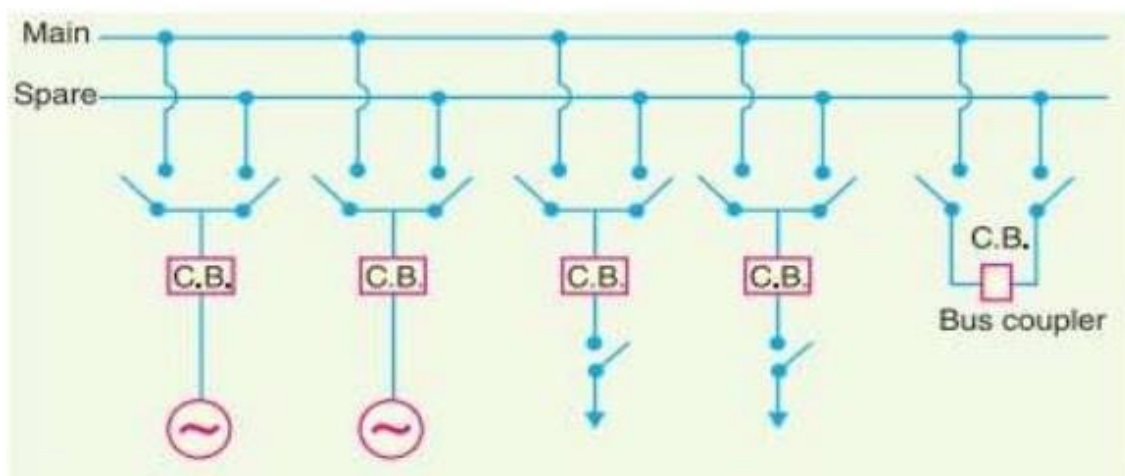

Duplicate bus-bar system

- Here main bus, spare bus and a bus-coupler employed.
- This arrangement is difficult in nature.
- Each generator ,feeder may be connected to either bus bar with the help of bus coupler which consists of CB and isolator.
- It will too expensive in nature.
- Repair and maintenance of main bus-bar easily without interrupting the supply.
- If fault occurs on the bus bar the continuity of supply can be maintained by transferring it to the other bus bar.

Switch gear accommodation: Depending upon the voltage to be handled switch gear may be broadly classified into:

- I. Outdoor type.
- II. Indoor type.

Outdoor type: Voltage above 66 kv, switch gear equipments are installed in outdoor ,this type is called as outdoor type accommodation.

Indoor type: For voltage below 66 kv ,switch gear equipments are installed in indoor, this type of accommodation is called as indoor type.

Short circuit: When ever a fault occurs on a network such that a large current flows in one or more phases ,a short circuit is said to have occurred.

Causes of short circuit: Causes of short circuit is two types:

Internal effects: Deterioration of insulation in a generator ,transformer etc.

External effects : Lightning surges ,over loading,mechanical damage by public.

Effects of short circuit:

- Interrupt the power supply.
- Heating the machines.

Faults in power system: A fault in an electrical equipment is defined as a defect in the electrical circuit due to which current is diverted into the intended path.

Faults are two types:

- 1. Symmetrical faults.
- 2. Un-symmetrical faults.

Symmetrical faults: The fault which gives rises to symmetrical fault currents(equal fault currents with 120° displacement) is called as symmetrical fault.

Example: All three phases to ground and all three phases short circuited.

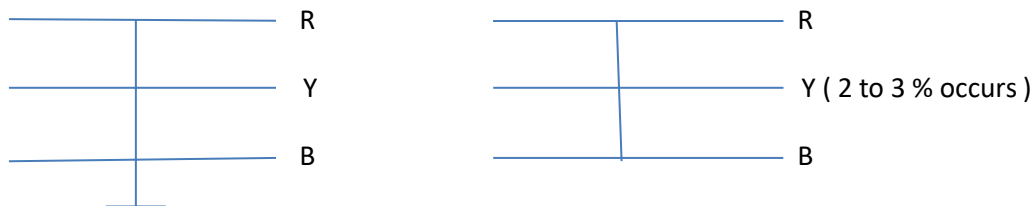

Unsymmetrical faults: The fault which gives rise to unsymmetrical currents (i.e equal line currents with unequal displacements) are called unsymmetrical faults.

Again the unsymmetrical faults are following types:

- Single line to ground (L-G)



- Phase to phase (L-L):



- Two phase to ground (L-L-G):

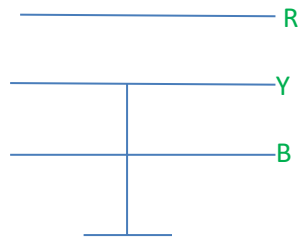

- Phase to phase and third phase to ground :

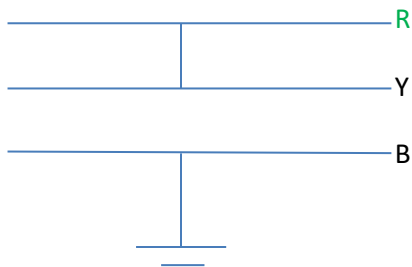

SHORT QUESTIONS WITH ANSWERS :

What are the essential features of

switchgear ?ANS: The essential features of

switchgear are

- complete reliability
- absolute certain discrimination
- quick operation
- provision for manual control
- provision for instrument

In which voltage bus-bar operates ?

ANS: Bus-bar operates at constant and variable voltage .

Which type of fault in power system is most frequent .

ANS: The most common type of fault in power system is single line to ground fault.

Q-4 What are the different type of bus bar arrangement in power system ?

ANS: The different bus-bar arrangements are

- single bus-bar arrangement
- single bus bar with sectionalisation
- duplicate bus-bar system

LONG QUESTIONS:

Q-1 State essential features of switchgear [2017(s),2018(s)]

Q-2 Explain about switch gear accommodation.

Q-3 Explain about various types of bus-bar arrangements.

END

FAULT CALCULATION

Symmetrical faults on 3- ϕ system: That fault on the power system which gives rise to symmetrical fault currents (i.e equal fault currents in the lines with 120° displacement) is called a symmetrical fault.

The symmetrical fault occurs when all the three conductors of a 3- ϕ line are brought together simultaneously.

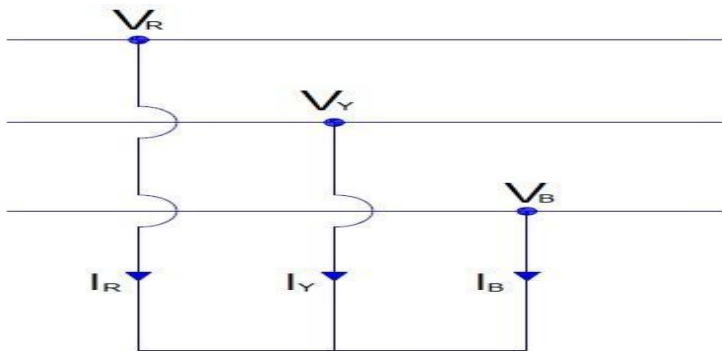

This fault is more dangerous in nature.

Limitation of fault current:

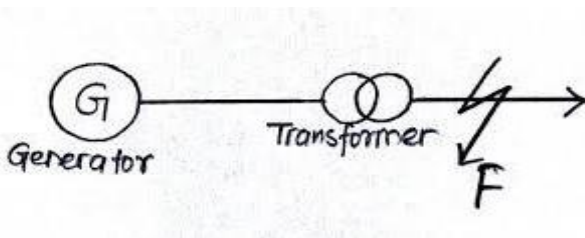

As shown in above figure, the fault occurs on the feeder at point F.

After that the short circuit current flow.

That short circuit current is limited by the impedance of the system up to the point of fault.

That's why the knowledge of impedances of the various equipment and circuits in the line of the system is very important when calculating the short circuit currents.

Percentage reactance: It is the percentage of the total phase-voltage dropped in the circuit when full load current is flowing.

$$\text{i.e } \% X = \frac{IX \times 100}{V} \text{-----(1)}$$

Where ,

I= full load current in A.

V=phase voltage in V.

X=reactance in Ω .

From equation (1),

$$X = \frac{\% X V}{I} \text{ , } \Omega$$

Multiplying and dividing the right hand expression by V,

$$X = \frac{(\% X) \times V \times V}{I \times V \times 100}$$

$$= \frac{(\% X) \times V^2}{V \times I \times 100}$$

When the voltage and the output are expressed in KV and KVA respectively, then

$$X = \frac{(\% X) \times (V/1000) \times (V/1000)}{(V/1000) \times (I /1000) \times 100}$$

$$= \frac{(\% X) \text{ KV} \times \text{KV}}{\text{KV} \times \text{KA} \times 100}$$

$$= \frac{(\% X) (\text{KV})^2 \times 1000}{\text{KV} \times \text{A} \times 100}$$

$$X = \frac{(\% X) \times (\text{KV})^2 \times 10}{\text{KVA}} \text{ in } \Omega.$$

$$\%X = \frac{X \times (\text{KVA})}{(\text{KV})^2}$$

$$10 \text{ (KV)}^2$$

If X is the only reactance element in the circuit ,then short circuit current is given by ,

$$I_{sc} = V/X \text{ -----(2)}$$

From equation (1)

$$V/X = I \times (100 / \%X)$$

Now this V/X put in equation (2) we get

$$I_{sc} = I \times (100 / \%X)$$

Percentage reactance and base KVA : We know that,

$$\% X = \frac{(\text{KVA}) \times X}{10(\text{KV})^2}$$

From above we see that % x depends upon the KVA rating

The common KVA rating among all equipments used in power system is known as base kva .

A base KVA may be chosen in the following manner ,

- Any arbitrary value.
- Equal to the KVA ratings of the largest unit connected in the network.
- Equal to the sum of the KVA ratings of all the units connected in the network.
- % age reactance at base KVA = $\frac{\text{Base KVA} \times \% \text{ age reactance at rated KVA}}{\text{Rated KVA}}$

Rated KVA

Short circuit KVA: The product of normal system voltage and short circuit current at the point of fault expressed in KVA is known as short circuit KVA.

So short circuit KVA FOR 3- ϕ circuit ,

$$\begin{aligned} &= \frac{3 V I_{sc}}{1000} \\ &= \frac{3 V \times I}{1000} \times \frac{100}{\%X} \\ &= \text{Base KVA} \times \frac{100}{\%X} \end{aligned}$$

% X

Reactor control of short circuit current :

- Reactor: The additional reactance (a coil of number of turns designed to have a large inductance) as compared to its ohmic resistance is known as reactor .
- Reactors limit the flow of short circuit current.
- Reactors permit the installation of circuit breakers of lower rating.
- Reactors are connected in series with the system.

Location of reactors: Short circuit current limiting reactors may be connected

- in series with generator.
- in series with each feeder.
- in bus bars.

Generator reactors:

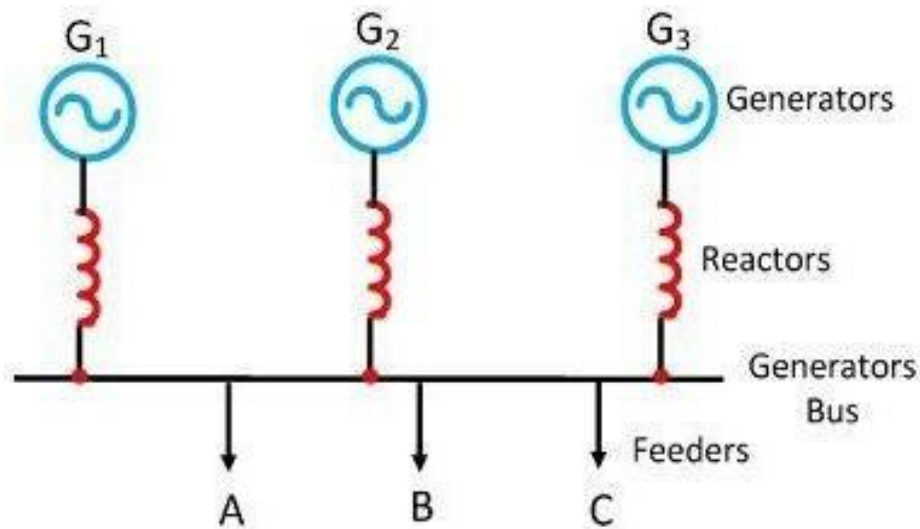

Generator Reactors

Circuit Globe

- when the reactors are connected in series with each generator ,they are known as generator reactors.
- In this arrangement generators are protected in the case of any short circuit beyond the reactors.
- There is a constant voltage drop and power loss in the reactors even during normal operation .
- If a fault occurs on any feeder, the continuity of supply is likely to be affected .
- If a bus bar or feeder fault occurs close to the bus bar the voltage at bus bar reduced.

Feeder reactors:

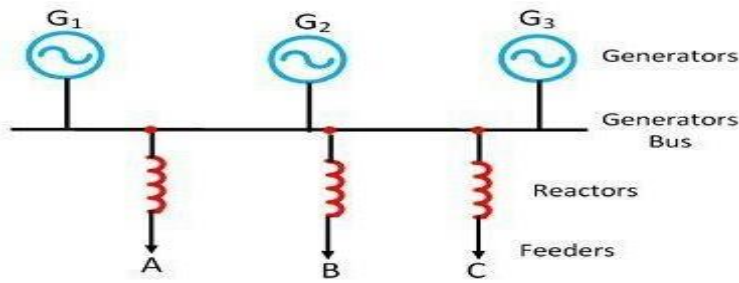

Feeder Reactors

Circuit Globe

- When the reactors are connected in series with each feeder, they are known as feeder reactors.
- Feeders are protected very safely.
- Bus bar voltage should be constant even if fault on any feeders.
- The fault on a feeder will not affect the other feeder.
- There is a constant voltage drop and power loss in the reactors even during normal operation.
- If short circuit occurs at the bus bar, no protection is provided to the generators.

Bus-bar reactors: Bus-bar reactors are two types:

- Ring system
- Tie-bar system

Ring system:

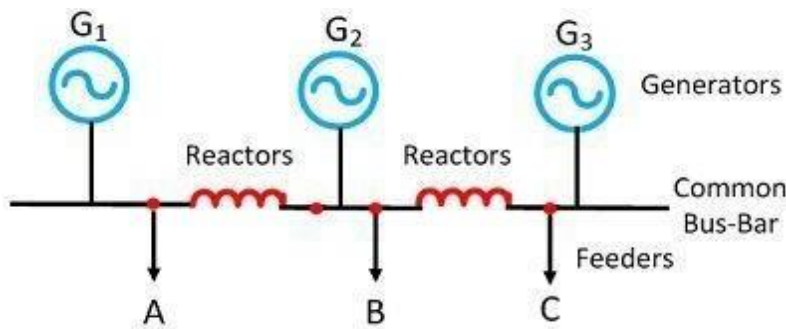

Bus-Bar Reactors (Ring System)

Circuit Globe

- In this system, bus-bar is divided into sections and these sections are connected through reactors.
- There is little power loss and voltage drops in the reactors.
- If fault occurs in any feeder, the continuity of supply to other feeders is not affected.

Tie-bar system:

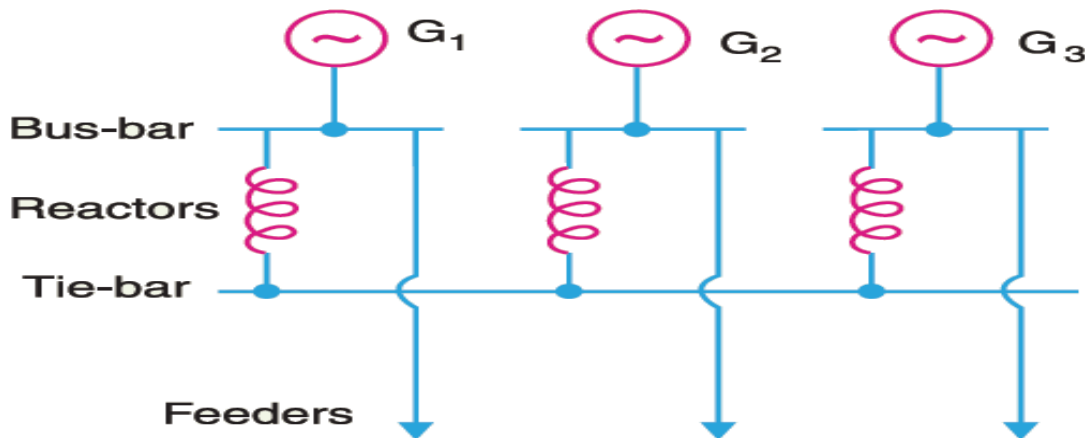

- In this system the additional bus-bar i.e tie-bar is employed .
- There are effectively two reactors in series between the sections.
- In the tie-bar system the additional generators may be connected to the system without requiring changes in the existing reactors..

Steps for symmetrical fault calculation:

- Draw a single line diagram of the network indicating the rating,voltage and percentage reactance of each element of the network.
- Choose the value of base KVA and convert all percentage reactance to this base value.
- According to single line diagram ,draw the reactance diagram.
- Find the total percentage reactanceof the network upto the point of fault .Let it be X %.
- Find full load current corresponding to the selected base KVA and the normal system voltage at the fault point.Let it be I.
- Then find out various short circuit calculations are :

Short circuit current ,

$$I_{sc} = I \times \frac{100}{\% X}$$

Short circuit KVA ,

$$= \text{Base KVA} \times \frac{100}{\% X}$$

NUMERICALS:

A 3-Phase, 20 MVA, 10 KV alternator has internal reactance of 5% and negligible resistance. Find the external reactance per phase to be connected in series with the alternator so that the steady current on short-circuit current does not exceed 8 times the full load current.

Solution:

$$\text{Full load current, } I = \frac{20 \times 10^6}{\sqrt{3} \times 10 \times 10^3} = 1154.7 \text{ A}$$

$$\text{Voltage per phase, } V = \frac{10 \times 10^3}{\sqrt{3}} = \frac{10000}{\sqrt{3}} \text{ V}$$

As the short circuit current is to be 8 times the full load current.

$$\begin{aligned} \therefore \text{Total percentage reactance required} &= \frac{\text{Full load current}}{\text{Short circuit current}} \times 100 \\ &= \left(\frac{1}{8}\right) \times 100 = 12.5\% \end{aligned}$$

$$\therefore \text{External percentage reactance required} = 12.5 - 5 = 7.5\%$$

Let $X \Omega$ be the per phase external reactance required.

$$\text{Now percentage reactance} = \frac{I X}{V} \times 100$$

$$7.5 = \frac{1154.7 X}{(1000/\sqrt{3})} \times 100$$

$$X = \frac{7.5 \times 10000}{\sqrt{3} \times 100 \times 1154.7} = 0.375 \Omega \text{ (Ans)}$$

A three phase transmission line operating at 10 kv and having a resistance of 1Ω and reactance of 4Ω is connected to the generating station bus bar through 5 MVA step-up transformer having a reactance of 5%. The bus bar are supplied by a 10 MVA alternator having 10% reactance. calculate the short circuit kva fed to a symmetrical fault between phases if it occurs

(a) at the end of the transmission line

(b) at the high voltage terminals of the transformer

Solution:

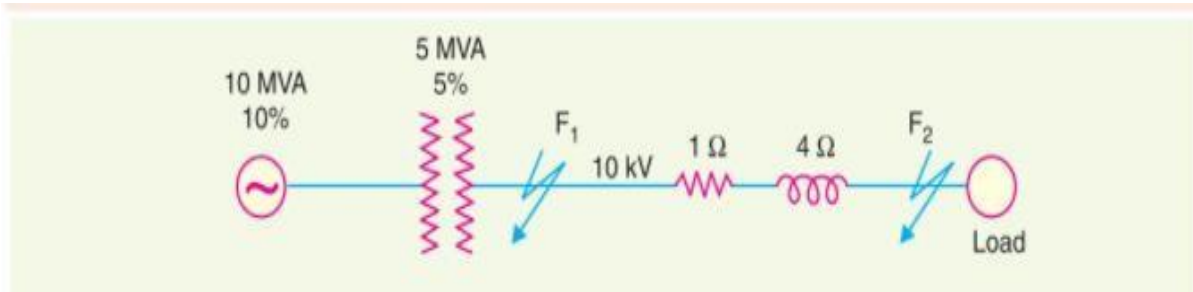

shows the single line diagram of the network. Let 10,000 kVA be the base

% reactance of alternator on base kVA,

$$\% X_A = \frac{10,000}{10 \times 10^3} \times 10 = 10\%$$

% reactance of transformer on base kVA,

$$\% X_T = \frac{10,000}{5 \times 10^3} \times 5 = 10\%$$

The line impedance is given in ohms. It can be converted into percentage impedance by using exp. (ii) of Art. 17.3.

% reactance of transmission line is

$$\begin{aligned} \% X_L &= \frac{(\text{kVA}) \times \text{reactance in } \Omega}{10 (\text{kV})^2} \\ &= \frac{10,000 \times 4}{10 \times (10)^2} = 40\% \end{aligned}$$

% age resistance of transmission line,

$$\% R_L = \frac{10,000 \times 1}{10 \times (10)^2} = 10\%$$

(i) The reactance diagram of the network on the selected base kVA is shown in Fig. 17.10. For a fault at the end of a transmission line (point F_2),

$$\begin{aligned} \text{Total \% reactance} &= \% X_A + \% X_T + \% X_L \\ &= 10 + 10 + 40 = 60\% \end{aligned}$$

$$\% \text{ resistance} = 10\%$$

\therefore % impedance from generator neutral upto fault point F_2

$$= \sqrt{(60)^2 + (10)^2} = 60.83\%$$

\therefore Short-circuit kVA = $10,000 \times 100/60.83 = 16,440 \text{ kVA}$

(ii) For a fault at the high voltage terminals of the transformer (point F_1),

Total % reactance from generator neutral upto fault point F_1

$$= \% X_A + \% X_T = 10 + 10 = 20\%$$

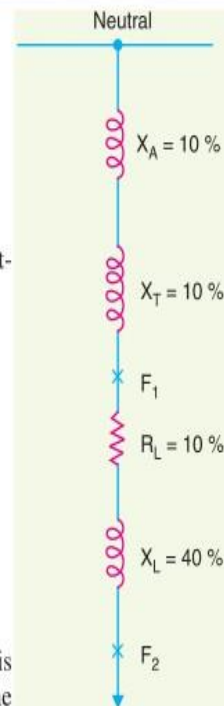

Fig. 17.10

Short circuit kva = $10000 \times (100/20) = 50,000 \text{ kva (Ans)}$

Q-3

Example 17.4. The plant capacity of a 3-phase generating station consists of two 10,000 kVA generators of reactance 12% each and one 5000 kVA generator of reactance 18%. The generators are connected to the station bus-bars from which load is taken through three 5000 kVA step-up transformers each having a reactance of 5%. Determine the maximum fault MVA which the circuit breakers on (i) low voltage side and (ii) high voltage side may have to deal with.

Solution. Fig. 17.11 shows the single line diagram of the network. Let 10,000 kVA be the base kVA.

The percentage reactance of generators A, B and C and that of each transformer on the selected base kVA is

$$\% X_A = 12 \times 10,000/10,000 = 12\%$$

$$\% X_B = 12 \times 10,000/10,000 = 12\%$$

$$\% X_C = 18 \times 10,000/5,000 = 36\%$$

$$\% X_T = 5 \times 10,000/5,000 = 10\%$$

- (i) When the fault occurs on the low voltage side of the transformer (point F_1 in Fig. 17.11), the reactance diagram at the selected base kVA will be as shown in Fig. 17.12. Obviously, the

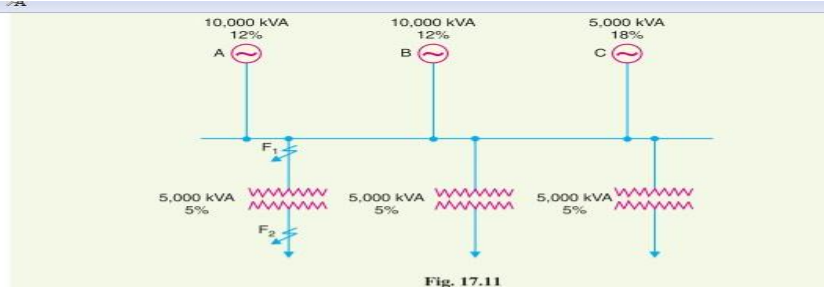

Fig. 17.11

total reactance upto the point of fault F_1 is the parallel combination of the reactances of the three alternators i.e.

$$\text{Total \% reactance from generator neutral upto fault point } F_1 \\ = \% X_A \parallel \% X_B \parallel \% X_C$$

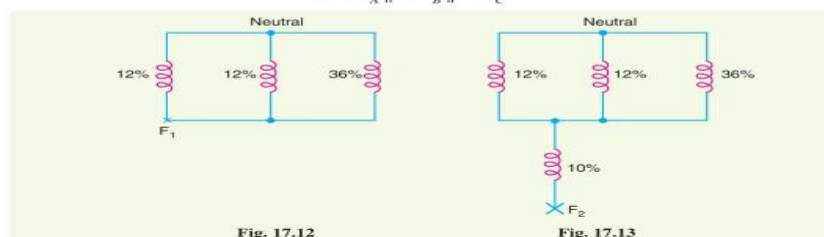

Fig. 17.12

Fig. 17.13

$$= 12\% \parallel 12\% \parallel 36\% = \frac{6 \times 36}{6 + 36} = 5.14\%$$

$$\therefore \text{Fault MVA} = 10,000 \times \frac{100}{5.14} \times \frac{1}{1000} = 194.5$$

- (ii) When the fault occurs on the high voltage side of the transformer (point F_2 in Fig. 17.11), the reactance diagram will be as shown in Fig. 17.13.

$$\text{Total \% reactance from generator neutral upto fault point } F_2 \\ = 5.14 + 10 = 15.14\%$$

$$\therefore \text{Fault MVA} = 10,000 \times \frac{100}{15.14} \times \frac{1}{1000} = 66$$

It may be noted that circuit breakers of lower ratings will be required on the high voltage side of the transformers.

SHORT QUESTIONS WITH ANSWERS:

What is symmetrical fault ?

ANS : That fault on the power system which gives rise to symmetrical fault currents (i.e equal fault currents in the lines with 120° displacement) is called a symmetrical fault.

Define percentage reactance .[2010(s),2012(s),2018(w),2019(s)]

ANS: It is the percentage of the total phase-voltage dropped in the circuit when full load current is flowing.

Define short circuit kva .[2015(s),2018(w)]

ANS: The product of normal system voltage and short circuit current at the point of fault expressed in KVA is known as short circuit KVA.

What is reactor ?

ANS: The additional reactance (a coil of number of turns designed to have a large inductance) as compared to its ohmic resistance is known as reactor .

Write the function of reactor .

ANS:

- Reactors limit the flow of short circuit current.
- Reactors permit the installation of circuit breakers of lower rating.
- Reactors are connected in series with the system.

LONG QUESTIONS :

With neat sketch explain about feeder reactors [2015(s)]

What are the types of reactors used in substation as per location? Explain relative advantages .[2014(s),2019(s)]

Explain different types of reactors [2016(s),2017(s)]

END

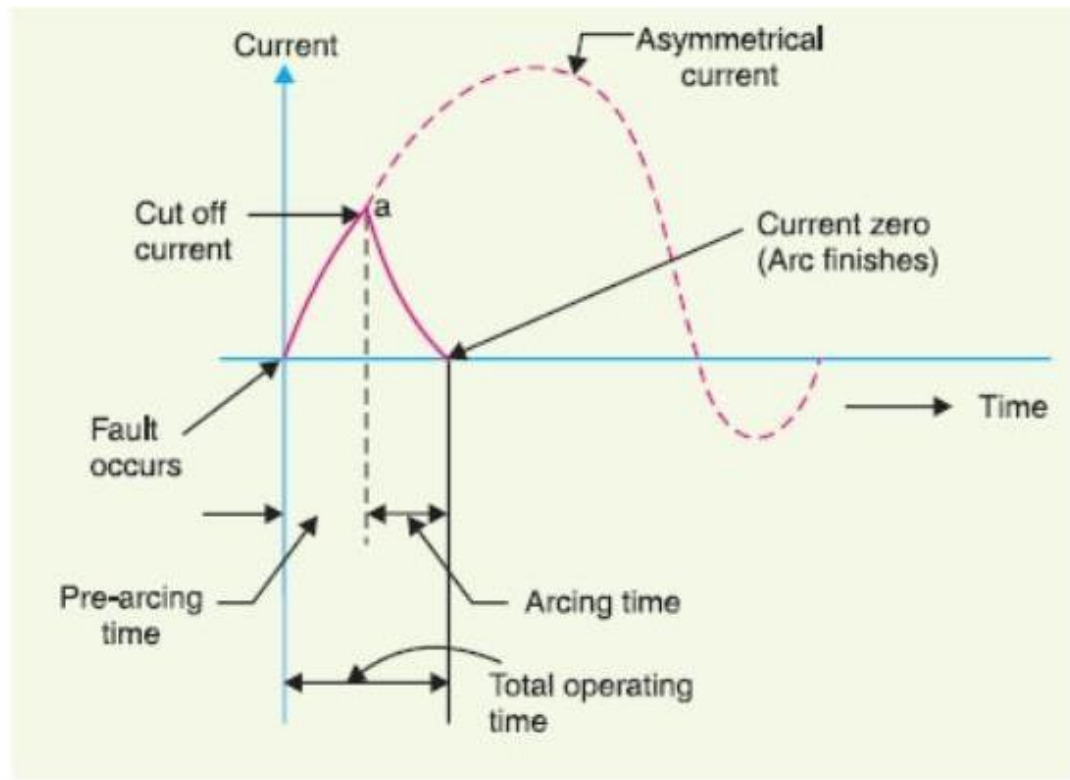

- **Cut-off current:** It is the maximum value of current actually reached before the fuse melts.
- **Pre-arcing time:** It is the time between the commencement of fault at the instant when cut-off occurs.
- **Arcing time:** This is the time between the end end of pre-arcing time and the instant when the arc is extinguished (finished).
- **Total operating time :** It is the sum of pre-arcing and arcing times.
- **Breaking capacity:** It is the RMS value of ac component of maximum prospective current that a fuse can deal with at rated service voltage.

Types of fuses: There are two types of fuses:

- Low voltage fuse
- High voltage fuse

Low voltages fuses: Low voltages fuses are two types:

- Semi-enclosed rewirable fuse(kit-kat type)
- High rupturing capacity (HRC) cartridge fuse
- HRC fuse with tripping device.

Semi-enclosed rewirable fuse:

- Semi-enclosed rewirable fuse also known as kit-kat type fuse.
- It consists of a base and a fuse carrier.
- The base is of porcelain and carries the fixed contacts to which the incoming and outgoing phase wires are connected.
- The fuse carriers is also of porcelain and holds the fuse element (tinned copper wire) between its terminals.
- When fault occurs the fuse element is blown out and the circuit is interrupted .
- Then the fuse carrier is taken out and blown out fuse element is replaced by the new one.
- The fuse carrier is then reinserted in the base to restore the supply.
- Standard rating of fuses are 6,16,32,63 and 100A.

High rupturing capacity (HRC) cartridge fuse:

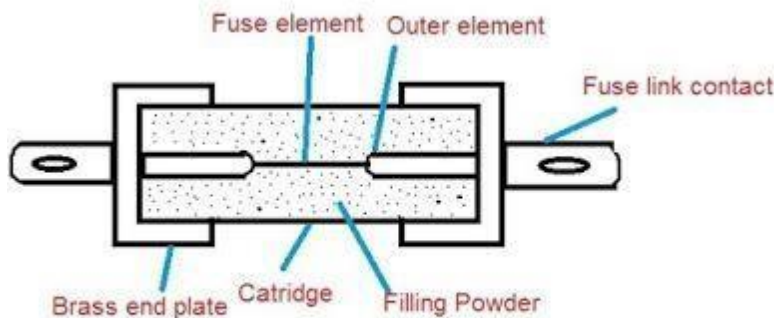

- It consists of heat resisting ceramic body having metal end caps.
- The filling powder (chalk,plaster of paris,quartz,marble dust) packed on the cartridge.
- Fuse element placed on the cartridge between outer element.
- Under normal load condition,the fuse element carries the normal current without overheating.
- When a fault occurs ,the fuse element melts due to increase in current in the circuit and then the circuit is interrupted.

Advantages:

- They are capable of clearing high as well as low fault currents.
- They donot deteriorate with age.
- They have high speed of operation.
- They provide reliable discrimination.
- They require no maintenance.
- They permit consistent performance.
- Disadvantages:

- They have to replace after each operation.
- Heat produced by the arc may affect the associated switches.

HRC fuse with tripping device:

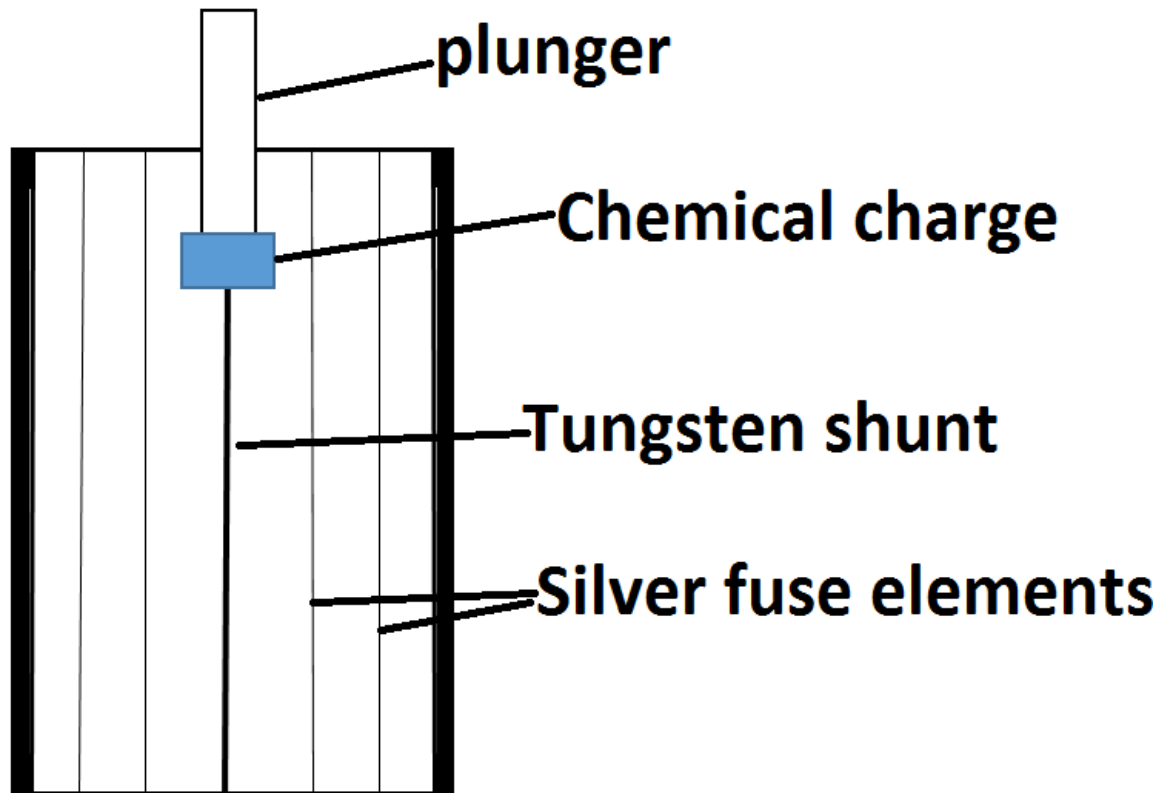

- The body of the fuse is of ceramic material with a metallic cap rigidly fixed at each end.
- The body contains number of silver fuse elements.
- The plunger is connected to the one end of the body to tripping mechanism of circuit breaker.
- The plunger is electrically connected through a fuse link, chemical charge and a tungsten wire to the other end of the cap.
- When a fault occurs, the silver fuse elements are the first to be blown out and then current is transferred to the tungsten wire.
- After some time tungsten wire gets fused and causes the chemical charges flows out.
- When charge flows out plunger should imbalance to operate the circuit breaker.
- Thus the circuit opened and interrupted the fault current.

High voltage fuse:

High voltage fuses are two types:

- Cartridge type
- Liquid type

Cartridge type:

- This is the similar construction as the low voltage cartridge type.
- Here only some special design arranged that there are two fuse element in parallel.
- One of low resistance (silver wire) and other high resistance (tungsten wire).
- Under normal condition the low resistance element carries the normal current.
- When a fault occurs the low resistance element is blown out and the high resistance element reduces the short circuit current and finally breaks the circuit.
- This fuse is used upto 33KV breaking capacity 8700A.

Liquid type:

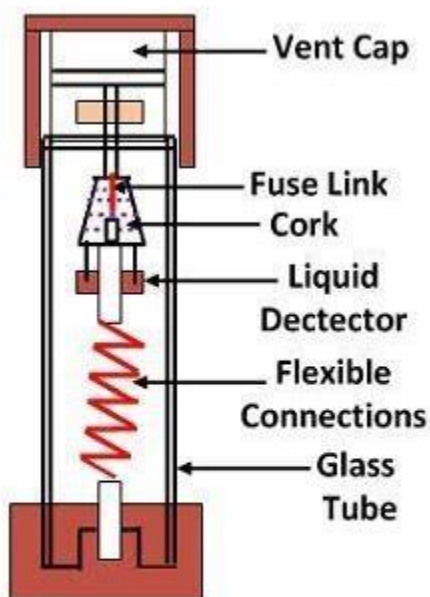

Liquid Type HV HRC Fuse

Circuit Globe

- It consists of a glass tube filled with carbon tetrachloride solution and sealed with brass caps.
- The fuse wire is sealed at one end of the tube and the other end of the wire is held by a strong phosphor bronze spiral spring fixed at the other end of the glass tube.
- When the current exceeds the prescribed limit the fuse wire is blown out.
- After that with the help of spring force ,liquid (carbon tetrachloride solution) flows to the fuse link and extinguishes the arc completely.
- And thus the circuit should interrupted.

Current carrying capacity of fuse element: The current carrying capacity of a fuse element depends upon the following factors:

- material of fuse element.
- length.
- diameter.
- size and location of terminals.

When the fuse element contains steady temperature ,

Heat produced = Heat lost per second by convection ,radiation and conduction.

$I^2R = \text{constant} \times \text{effective surface area.}$

$$\Rightarrow I^2 \rho (l/a) = \text{constant} \times d \times l$$

Where ,

d= diameter of fuse element

l=length of fuse element

$$I^2 \left(\frac{\rho l}{\pi/4 d^2} \right) = \text{constant} \times d \times l$$

$$I^2 = \text{constant} \times d^3$$

$$I^2 \propto d^3$$

$$\Rightarrow I \propto d^{3/2}$$

$$\Rightarrow I = K d^{3/2}$$

Where K is a constant ,called the fuse constant.It's value depends upon the metal of which the fuse element is made.

Difference between a fuse and circuit breakers:

SL NO	PARTICULARS	FUSE	CIRCUIT BREAKER
01	Function	It performs both detection and interruption function.	It performs interruption function.The detection of fault is made by relay system.
02	Operation	Completely automatic	For complete automatic ,relay's are used
03	Breaking capacity	Small	Very large

04	Operating time	Very small (0.002 sec or so)	Comparatively large(0.1 to 0.2 sec)
05	Replacement	Requires replacement after every operation	No replacement after operation.

SHORT QUESTIONS WITH ANSWERS:

Write difference between fuse and circuit breaker ? [2018(s)]

ANS : Fuse: It is the voltage that appears across the contacts of the circuit breaker during the arcing period.

Circuit breaker : A circuit breaker is a piece of equipment which can make or break a circuit either manually or by remote control under normal condition ,break a circuit automatically under fault conditions ,make a circuit either manually or by remote control under fault condition.

Define fusing factor .[2016(s),2017(s)]

ANS: It is the ratio of minimum fusing current to the current rating of the fuse element.

$$\text{Fusing factor} = \frac{\text{minimum fusing current}}{\text{current rating of fuse}}$$

What are the common materials used for fuse element ? [2014(s)]

ANS: The common materials used for fuse elements are lead ,tin,copper,zinc and silver.

LONG QUESTIONS :

With neat sketch explain about HRC type of fuse .[2014(s),2015(s),2019(s)]

Write short notes on difference between a fuse and circuit breaker [2018(s),2019(s)]Q-3

Define prospective current and cut-off current [2016(s),2017(s)]

Explain HRCfuse with tripping device [2016(s),2017(s)]

Draw wave diagram of current and explain briefly cut-off current ,pre-arcing time,arcing time [2015(s)]

END

CIRCUIT BREAKERS

Circuit breaker: A circuit breaker is a piece of equipment which can make or break a circuit either manually or by remote control under normal condition ,break a circuit automatically under fault conditions ,make a circuit either manually or by remote control under fault condition.

Symbol of circuit breaker

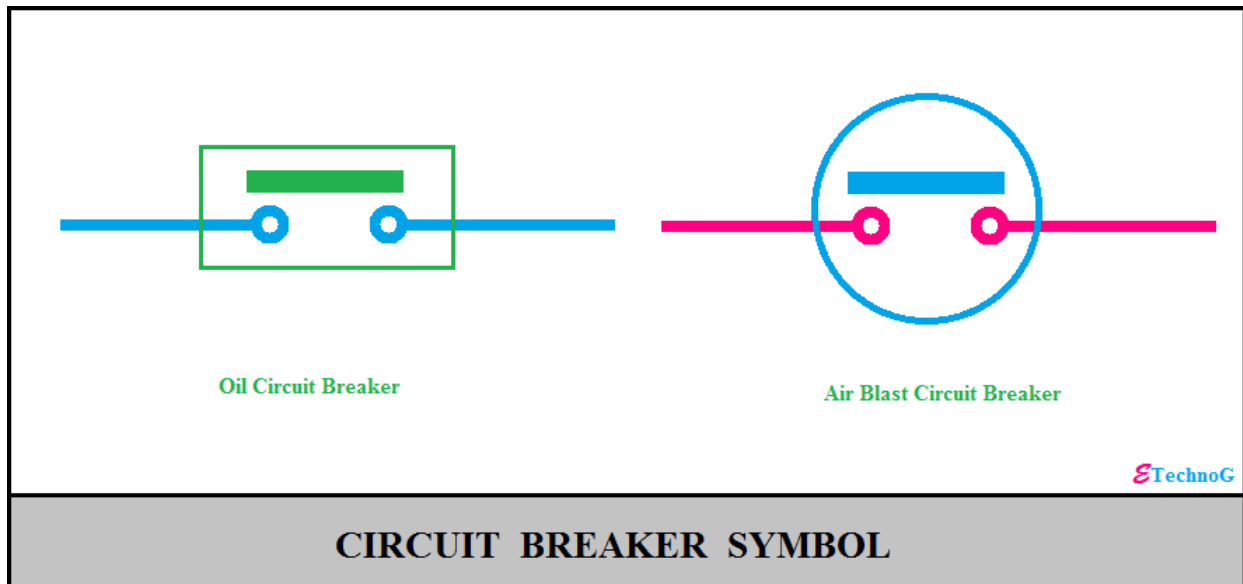

Operating principle: A circuit breaker consists of fixed and moving contacts. Under normal operating condition, these contacts remain in a closed position. These contacts can be opened manually or by remote control whenever desired. When a fault occurs on any part of the system, the trip coil of the circuit breaker gets energized and the moving contacts are pulled apart by some mechanism, thus opening the circuit.

Arc phenomenon:

- When a short circuit occurs, a heavy current will flow through the contacts of the circuit breaker before it opens.
- After the contacts open, the heat produced in the medium (oil or air) between the contacts.
- The heat is sufficient to ionize the air or vaporize and ionize the oil.
- The ionized air or vapor acts as a conductor and an arc is found between the contacts.

Principle of arc extinction : These are two factors which are responsible for maintaining the arc between the contacts as follows below:

- p.d between the contacts.
- ionized particles between the contacts.

Methods of arc extinction: There are two methods of extinguishing the arc in the circuit breakers,

- High resistance methods.
- Low resistance methods or current zero method.

High resistance method:

- In this method the arc resistance is made to increase with time so as the current is reduced to a value insufficient to maintain the arc.
- Consequently ,the current is interrupted or the arc is extinguished.

The resistance of the arc may be increased by,

- Lengthening the arc.
- Colling the arc.
- Reducing X-section of the arc.
- Splitting the arc.

Low resistance or current zero method:

- In this method the arc resistance is kept low until current is zero where the arc extinguishes naturally and is prevented from restriking inspite of the rising voltage across the contacts.
- In this method the dielectric strength of the medium between contacts increased immediately after current zero.

The rapid increased of dielectric strength (insulating properties) of the medium near zero can be done by or this can be achieved by ,

- lengthening of the gap.
- high pressure.
- colling
- blast effect.

Important terms:

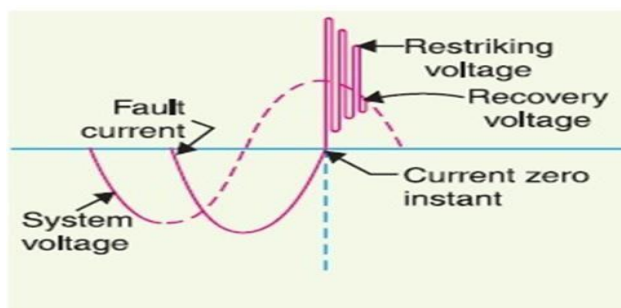

- **Arc voltage:** It is the voltage that appears across the contacts of the circuit breaker during the arcing period.
- **Restricting voltage:** It is the transient voltage that appears across the contacts at or near current zero during arcing period.
- **Recovery voltage:** It is the normal frequency (50 Hz) rms voltage that appears across the contacts of the circuit breaker after final arc extinction ,It is approximately equal to the system voltage.

Classification of circuit breakers: Accordingly on the basis of medium used for arc extinction ,circuit breaker may be classified into ,

- Oil circuit breakers
- Air blast circuit breakers
- Sulphur hexafluoride circuit breakers (SF₆)
- Vacuum circuit breakers

Oil circuit breakers:

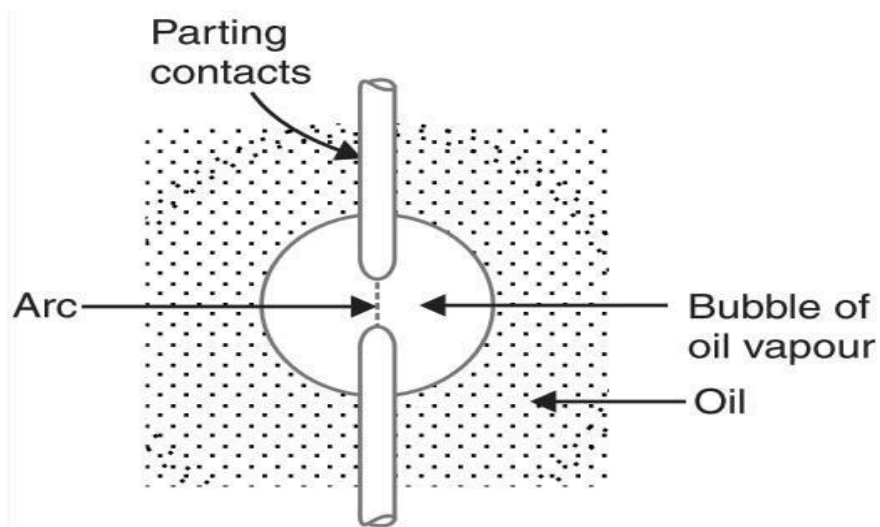

- In OCB there are two contacts , one is moving contact another is fixed contact.
- The transformer oil is used for arc quenching medium .
- The contacts are open under oil and an arc is struck between them.
- The heat of the arc evaporates the surrounding oil.
- Then the oil dissociates into a substantial volume of gaseous volume (one thousand times).
- Therefore the oil is pushed away from the arc ,thus the arc extinction takes place and circuit is interrupted .

Advantages: The advantages of oil as arc quenching medium are :

- It has excellent cooling properties.

- It acts as good insulator.

Disadvantages: The disadvantages of oil as arc quenching medium are :

- It is inflammable and there is a risk of fire.
- It may form explosive mixture of air.

Types of oil circuit breakers : There are two types of oil circuit breakers,

- Bulk oil circuit breaker.
- Low oil circuit breaker.

Again bulk oil circuit breaker are two types

- Plain break oil circuit breaker
- Arc control oil circuit breaker

Plain break oil circuit breaker:

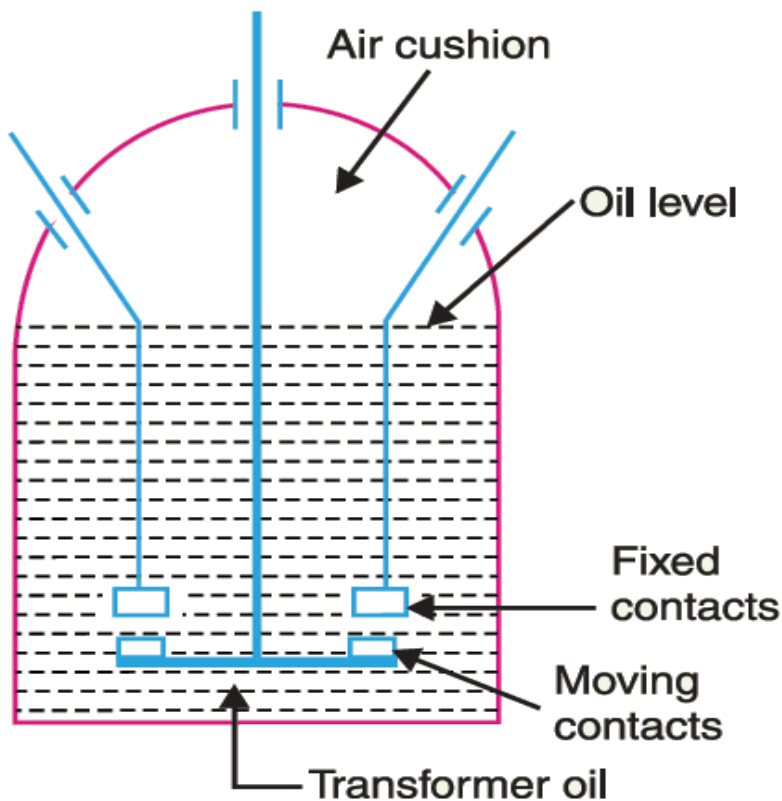

Construction:

- It has a strong weather tight tank.
- The tank contains transformer oil upto a certain level.
- The air cushion present above the oil level.
- The fixed contact and moving contact enclosed in the tank.

Operation: Under normal operating conditions, the fixed contact and moving contacts remain closed and the breaker carries the normal circuit current .When fault occurs ,the moving contacts are pulled down by the protective system and an arc is struck which vapourises the oil mainly into hydrogen, The hydrogen plays vital rule to extinguished the arc and the circuit current is interrupted.

Disadvantages:

- There is no special control over the arc.
- These breakers have long and inconsistent arcing times.
- These breakers donot permit high speed interruption.

Arc control oil circuit breakers: In arc control oil circuit breakers special arc control devices are employed for arc extinction purposes efficiently as possible.

These are two types of such breakers namely:

- Self-blast oil circuit breakers.
- Forced-blast oil circuit breakers.

Self-blast oil circuit breakers:

- In self-blast oil circuit breakers arc control is provided by internal means i.e the arc itself is employed for its own extinction efficiently.
- An insulating rigid pressure chamber or pot is installed surrounding the contacts.
- Here the arc gases is restricted by the chamber , a very high pressure is developed to force the oil and gas through or around the arc to extinguish it .
- The magnitude of pressure developed depends upon the value of fault current to be interrupted

Several design of pressure chamber are described below :

- Plain explosion pot
- Cross-jet explosion pot.
- Self-compensated explosion pot.

Plain explosion pot:

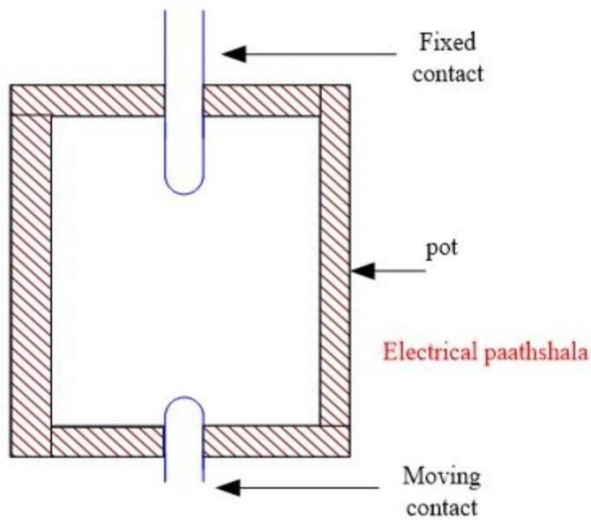

PLAIN EXPLOSION POT

- It is a rigid cylinder of insulating material and enclosed the fixed and moving contacts.
- The moving contact is a cylindrical rod passing through a throat at the bottom.
- When fault occurs ,the contact get separated and an arc is struck between them.
- The heat of the arc decomposes oil into a gas at a very high pressure in the pot.
- This high pressure forces the oil and gas through and around the arc to extinguished it.

Cross-jet explosion pot:

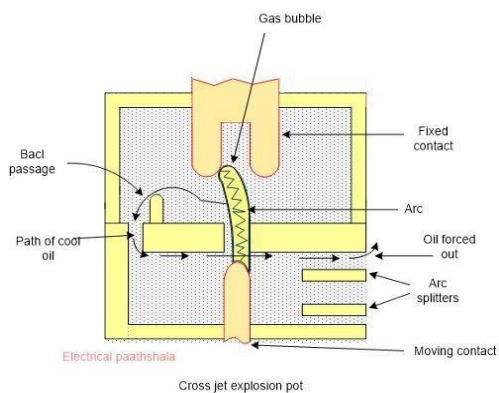

- It is made of insulating material.
- It has channels on one side which acts as arc splitters.
- The arc splitters helps in increasing the arc length ,thus facilitating arc extinction.
- By back passage (arc gases) the cool oil flow right angle to the arc .
- Thus the arc driven sideways into the arc splitters which increase the arc length , causing arc extinction.
- It is used for interrupting heavy fault current.

Self-compensated explosion pot:

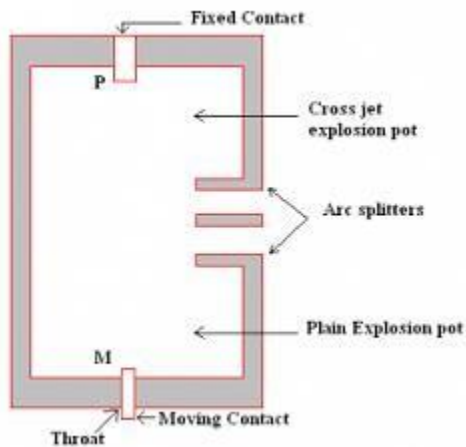

- This pot is combination of plain explosion pot and cross-jet explosion pot.
- This pot is used to interrupted low as well as heavy short circuit current.
- This pot consists of two chamber.
- Lower chamber is the plain explosion pot.
- Upper chamber is the cross-jet explosion pot.
- When short circuit current is heavy the device behaves as a cross-jet explosion pot.
- When short circuit current is low, the device behaves as a plain explosion pot.

Forced blast oil circuit breaker:

- Here pressure is generated by mechanically.
- That means oil pressure is created by the piston cylinder arrangement.
- When fault occurs ,the contact get separated by the protective system and an arc is stuck between the contact.
- Then the piston forces a jet of oil towards the contact gap extinguish the arc.

Low oil circuit breakers:

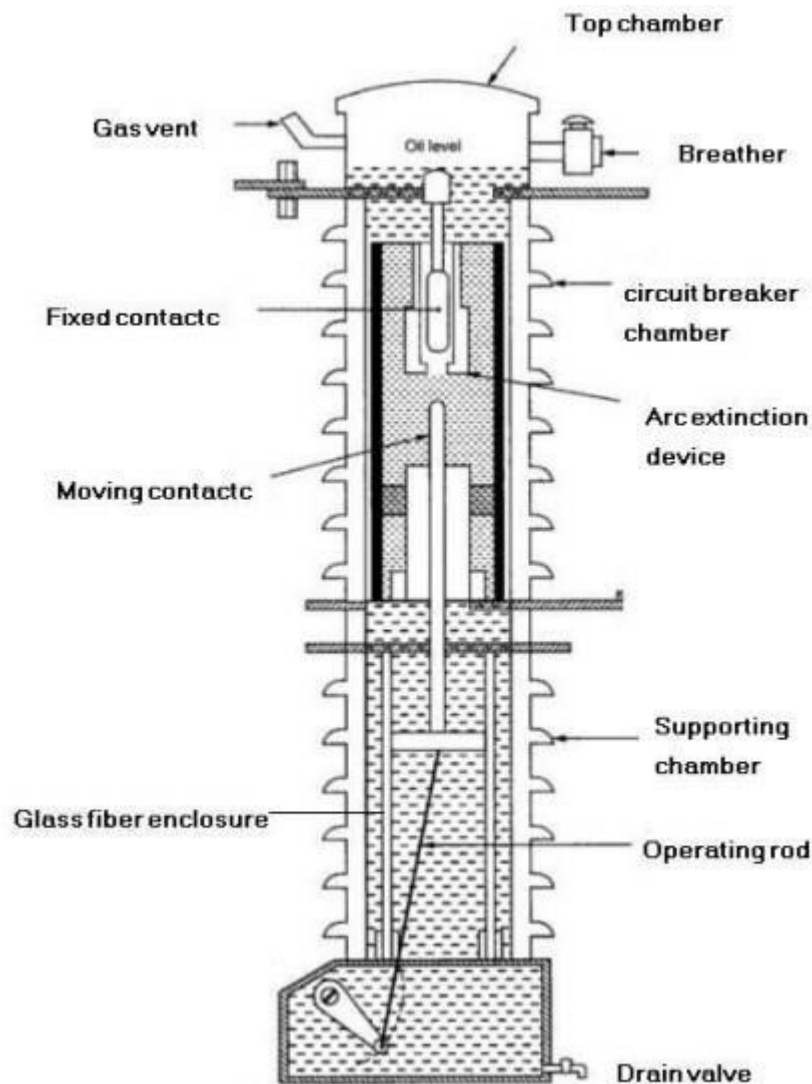

Construction: The low oil circuit breaker has the following parts :

supporting chamber:

- It is a porcelain chamber mounted on a metal chamber.
- It is filled with oil which is physically separated from the oil in the circuit breaking compartment.
- The oil inside the supporting chamber is employed for insulation purposes only.

Circuit breaking chamber:

- It is a porcelain enclosure mounted on the top of the supporting compartment.
- It is filled with oil .

It has following parts

- upper and lower fixed parts.
- moving contacts.
- turbulator.

Top chamber:

- It is a metal chamber.
- It is mounted on the circuit-breaking chamber.
- It provides expansion space for the oil in the circuit breaking compartments.

Operation:

- Under normal operating condition the moving contact are closed with each other.
- When a fault occurs ,the moving contact is pulled down by the tripping spring and an arc is struck.
- The arc vaporizes the oil and produces gases under high pressure.
- The high pressure gas is sprayed seriesly to the arc by turbulator,thus arc is extinguished .Then the circuit current is interrupted.

Advantages: A low oil circuit breaker has the following advantages over a bulk oil circuit breaker.

- It requires less quantity of oil.
- It requires smaller space.
- There is reduced risk of fire.
- Maintenance problems are reduced.

Disadvantages: A low oil circuit breaker has the following disadvantages as compared to bulk oil circuit breaker.

- Due to smaller quantity of oil , the degree of carbonization is increased .
- There is difficulty of removing the gases from the contact space in time.
- The dielectric strength of the oil deteriorates rapidly due to high degree of carbonization.

Maintenance of oil circuit breakers:

- Check the current carrying parts and arcing contacts.If the burning is severe ,the cotacts should be replaced.
- Check the dielectric strength of the oil.If the oil is badly discoloured ,it should be changed or reconditioned .The oil in good conditition should withstand 30KV for one minute in a standard oil testing cup with 4 mm gap between electrodes.
- Check the insulation possible damage.
- Clean the surface and remove carbon deposits with a strong and dry fabric.
- Check the oil level.
- Check closing and tripping mechanisim.

Air-blast circuit breakers:

- These breakers employ a high pressure air blast as an arc quenching medium.
- The air blast cools the arc and keeps away the arcing products to the atmosphere .
- This rapidly increases the dielectric strength of the medium between contacts and prevents from re-establishing the arc.
- Consequently the arc is extinguished and flow of current is interrupted.

Advantages: An air blast circuit breaker has the following advantages over an oil circuit breaker.

- The risk of fire is eliminated.
- The arcing time is very small.
- The size of the circuit breaker is reduced.
- The arcing product is completely removed by the blast.

Disadvantages:

- Maintenance is required for the compressor plant.
- It has sensitive to the rate of rise of restriking voltage.
- The air has an inferior arc extinguishing properties.

Classification of air-blast circuit breakers: Depending upon the direction of air blast in relation to the arc,air blast circuit breakers are classified into:

- Axial-blast type.
- Cross-blast type.
- Radial-blast type.

Axial blast type:

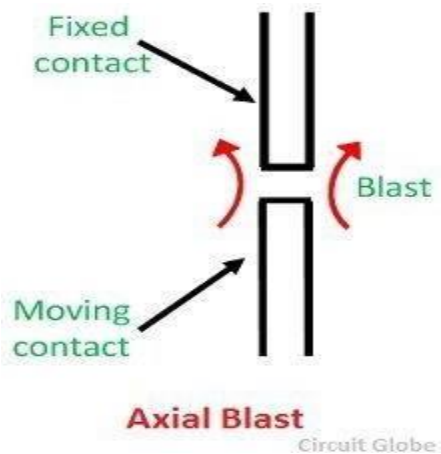

Here the air blast directed along the arc path.

Cross-blast type:

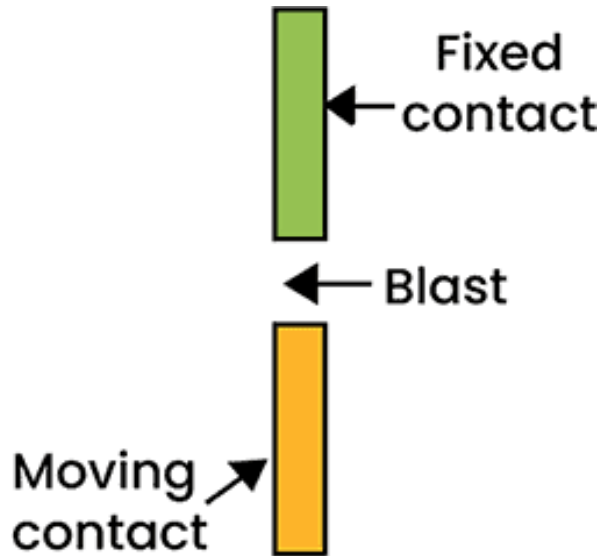

Here the air blast is directed at right angles to the arc path.

Radial-blast type:

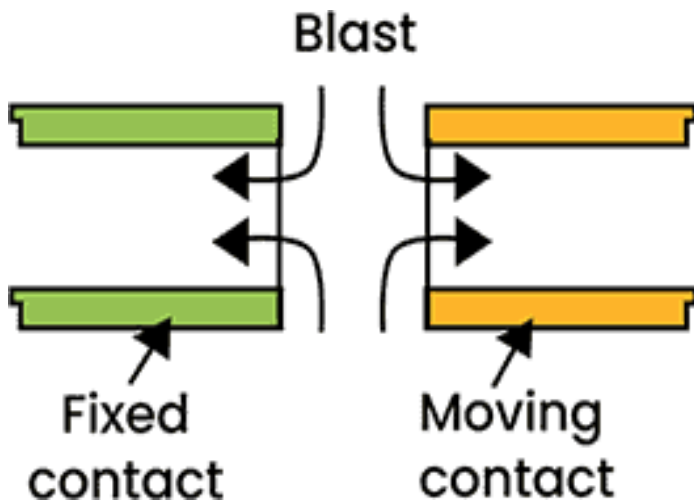

Here the air-blast is directed radially to the arc path.

Sulphur hexafluoride (SF₆) circuit breaker:

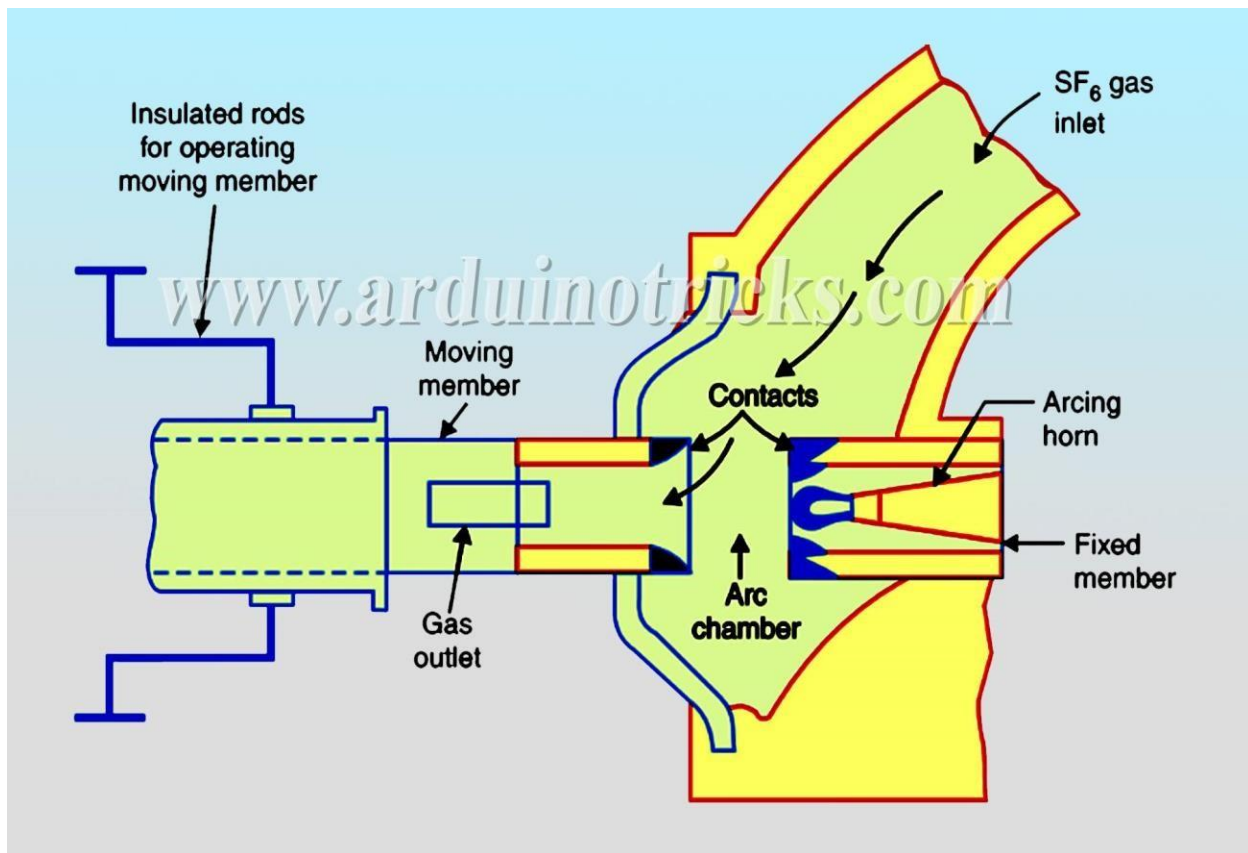

Construction:

- It consists of fixed and moving contacts enclosed in a chamber.
- Fixed contact is a hollow cylindrical current carrying contact fitted with an arc horn.
- The moving contact is also a hollow cylinder with rectangular holes.
- The tips of fixed contact, moving contact and arcing horn are coated with copper-tungsten arc resistant material.
- The enclosed chamber called arc interruption chamber containing SF₆ gas.
- This chamber is connected to a SF₆ gas reservoir.

Working:

- Under normal operating condition the contact remain closed by SF₆ gas at a pressure of about 2.8 kg/cm².
- When breaker operates, the moving contact is pulled apart and an arc is struck between the contacts.
- The movement of the moving contact is connected with the opening of a valve which permits SF₆ gas at 14 kg/cm² pressure from the reservoir to the arc interruption chamber.
- The high pressure flow of SF₆ rapidly absorbs the free of electrons in the arc path to form immobile negative ions which are ineffective as charge carriers.

- The result is that the medium between the contacts quickly builds up high dielectric strength and causes the extinction of the arc.

Advantages: SF₆ circuit breaker have many advantages over oil or air circuit breaker as follows below:

- It has very short arcing time.
- It can interrupt much larger current.
- It has gives noiseless operation.
- There is no risk of fire in such breakers because SF₆ gas is non-inflammable.
- There are no carbon deposits so that tracing and insulation problems are eliminated.
- The SF₆ breakers have low maintenance cost, light foundation requirement.

Disadvantages:

- SF₆ breakers are costly due to high cost of SF₆.
- Imperfect joints lead to leakage of SF₆ gas.
- Arced SF₆ gas is poisonous and should not be inhaled or let-out.

Vacuum circuit breakers (VCB):

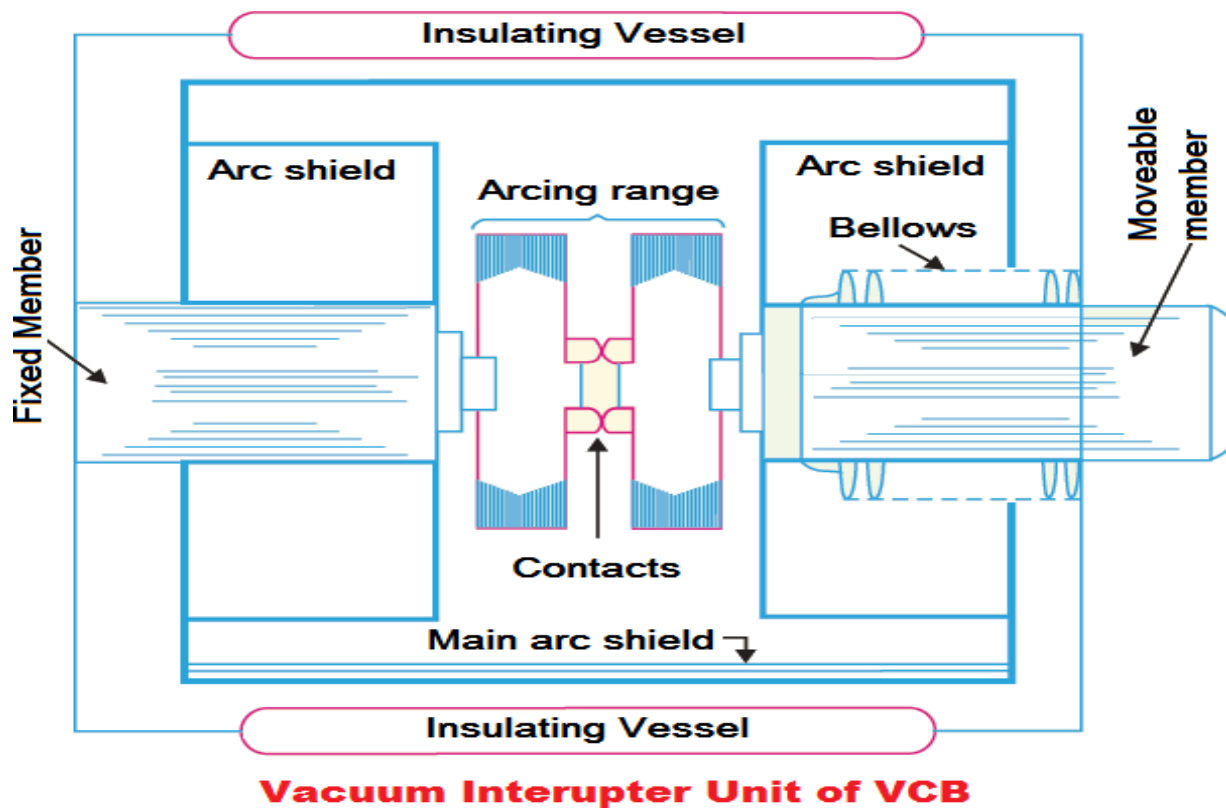

Construction:

- It consists of fixed contact, moving contact and arc shield mounted inside a vacuum chamber .
- The movable member is connected to the control mechanism by stainless steel bellows.
- This enables the permanent sealing of the vacuum chamber so as to eliminate the possibility of leak .
- A glass vessel or ceramic vessel is used as the outer insulating body .
- The arc shield prevents the deterioration of the internal dielectric strength by preventing metallic vapours falling on the inside surface of the outer insulating cover.

Working:

- Under normal condition fixed contact and moving contact are in closed.
- When breaker operates the moving contact separates from the fixed contact and an arc is struck between the contacts.
- The production of arc is due to ionization of metal ions and depends very much upon the material of the contact.
- The arc is quickly extinguished because the metallic vapours ,electrons and ions produced during arc are diffused in a short time and seized by the surfaces of moving and fixed members and shields.

Advantages: Vacuum circuit breaker has the following advantages:

- They are compact, reliable and have longer life.
- There are no fire hazards.
- There is no generation of gas during after operation.
- They can interrupt any fault current.
- They require little maintenance and are quiet in operation.
- They can successfully withstand lightning surges.
- They have low arc energy.
- They have low inertia and hence require smaller power for control mechanism.

Switchgear components: The following are the important components common to most of the circuit breakers:

- Bushings
- Circuit breaker contacts
- Instrument transformers
- Bus-bars and conductors

Bushings: When a high voltage passes through a metal sheet or frame which is at earth potential , the necessary insulation is provided in the form of bushing.

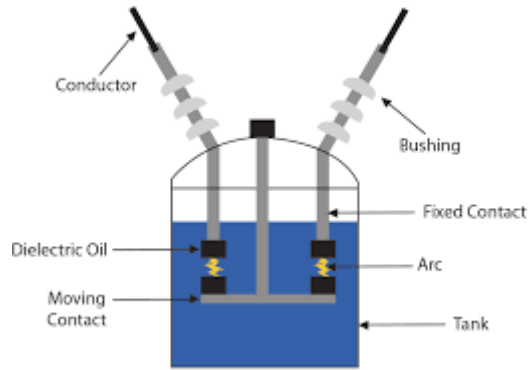

Circuit breaker contacts : The circuit breaker cotacts are required to carry normal as well as short circuit current.

Circuit breaker contacts are following types :

Tulip type contact:

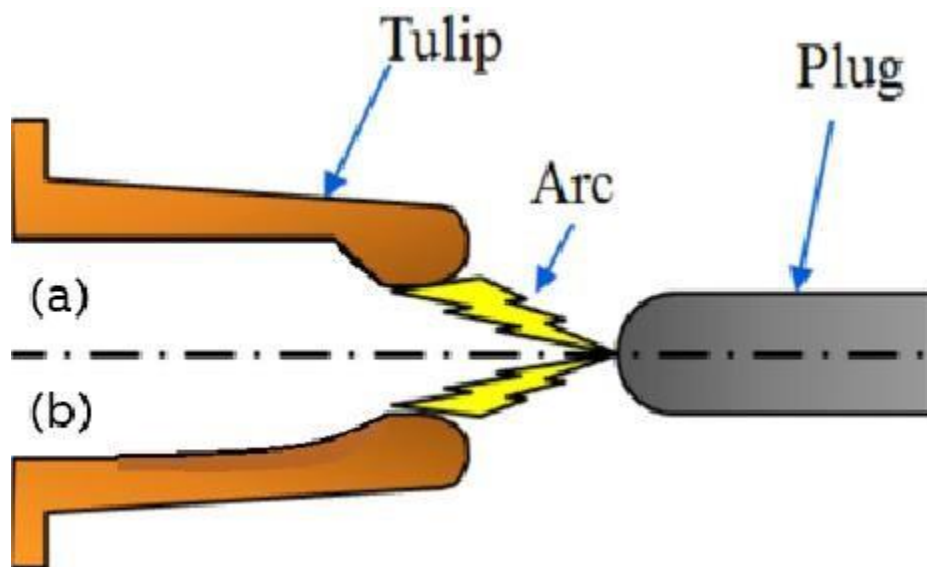

Finger and wedge contact and butt contact:

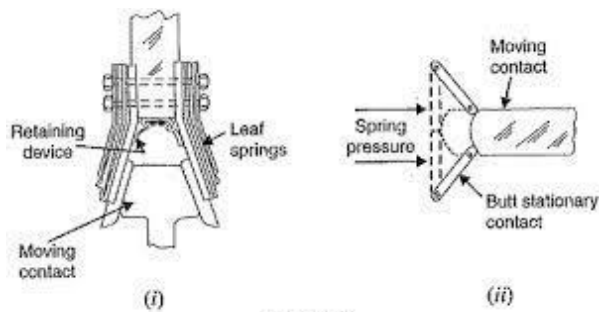

- This type of contact is largely used for low voltage oil circuit breakers owing to the general unsuitability for use with arc control devices.
- Butt contacts are useful in single break oil circuit breakers and air blast circuit breakers .
- There is no grip force so that this type of contact is specially suitable for higher short circuit rating.

Instrument transformer : For measuring high voltage , high current and for relay operation the instrument transformer is connected to circuit breakers.

The instrument transformers are two types:

- Current transformer
- Potential transformer

Bus-bars and conductors:

- The current carrying members in a circuit breaker consists of fixed and moving contacts and the conductors connecting these to points external to the breaker.
- If the switchgear is of outdoor type ,these connections are connected directly to the overhead lines.
- In case of indoor switchgear ,the incoming conductors to the circuit breaker are connected to the bus-bars.

Problems of circuit interruption :

Rate of rise of restriking voltage (RRRV):

- It is the rate of increase of restriking voltage.
- The unit of RRRV is KV/ μ sec.
- If RRRV greater than the rate of rise of dielectric strength between the contacts ,the arc will restrike.
- However the arc will fall to restrike if RRRV is less than the rate of increase of dielectric strength between the contact of the breaker .

Current chopping:

- It is the phenomenon of current interruption before the natural current zero is reached.
- Current chopping mainly occurs in air blast circuit breakers because they retain the same extinguishing power irrespective of the magnitude of the current to be interrupted.

Capacitive current breaking :

- Another cause of excessive voltage surges in the circuit breakers is the interruption of capacitive current

- Examples of such instances are opening of an unloaded long transmission line, disconnecting a capacitor bank used for power factor improvement.

Resistance switching :

- In power system due to current chopping , capacitive current breaking etc give rise to severe voltage oscillations.
- These excessive voltage surges during circuit interruption can be prevented by the use of shunt resistance R connected across the circuit breaker contacts is known as resistance switching.

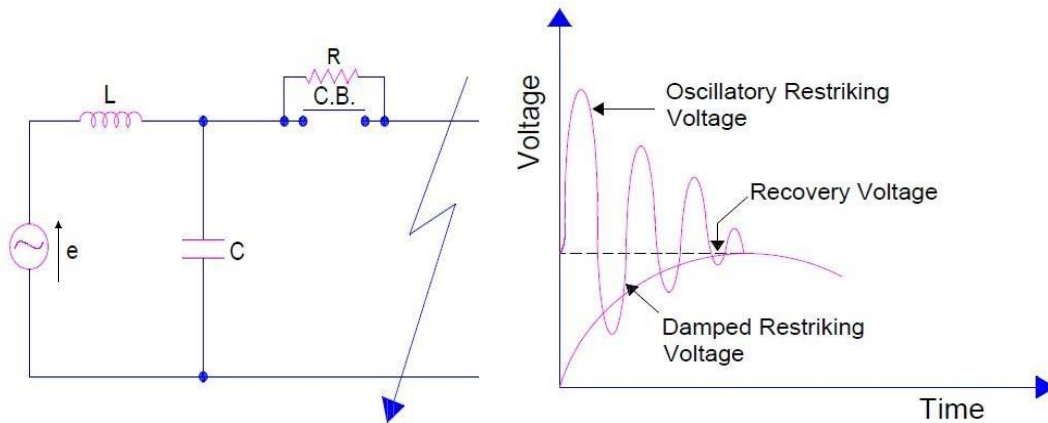

- When a fault occurs ,the contact of the circuit breaker opened and an arc is struck between the contacts
- Since the contacts are shunted by resistance R apart of arc current flows through this resistance.
- This results in the decrease of arc current and an increase in the rate of de-ionisation of arc path and consequently the arc resistance is increased.
- The increased arc resistance leads to further increase in current through shunt resistance.
- This process continues until the arc current become so small that it falls to maintain the arc.
- Now the arc is extinguished and circuit current is interrupted .

Circuit breaker ratings :

The circuit breakers have three ratings i.e

- Breaking capacity in MVA.
- Making capacity in KA,MA.
- Short-time capacity in sec.

Breaking capacity: It is current (rms) that a circuit breaker is capable of breaking at given recovery voltage and under specified conditions (e.g power factor, rate of rise of restriking voltage).

Making capacity: The peak value of current (including dc component) during the first cycle of current wave after the closure of circuit breaker is known as making capacity .

Short time rating : It is the period for which the circuit breaker is able to carry fault current while remaining closed.

Short questions with answer:

What is circuit breaker ? [2010(s),2007 (w)]

ANS : A circuit breaker is a piece of equipment which can make or break a circuit either manually or by remote control under normal condition ,break a circuit automatically under fault conditions ,make a circuit either manually or by remote control under fault condition

Name the quenching medium used in circuit breaker [2015(s)]

ANS : Quenching medium used in circuit breaker are transformer,air,vaccum,SF₆ .

Q-3 Why AC circuit is more easily interrupted than DC circuit .[2015 (s)]

ANS : AC circuit is more easily interrupted than DC circuit because in an AC system current drops to zero after every half cycle.

Q-4 Define restriking voltage. [2016(s),2017(s),2018(w),2019(s)]

ANS : It is the transient voltage that appears across contacts at or near current zero during arcing period.

Q-5 What is short time rating of circuit breaker ? [2016(S),2017(S)]

ANS : It is the period for which the circuit breaker is able to carry fault current while remaining closed.

Q-6 Define recovery voltage ? [2018 (S),2018(W)]

ANS : It is the normal frequency (50 Hz) rms voltage that appears across the contacts of the circuit breaker after final arc extinction ,It is approximately equal to the system voltage.

Q 7 What is arc voltage ? [2018 (w), 2019(s)]

ANS : It is the voltage that appears across the cotacts of the circuit breaker during the arcing period.

LONG QUESTIONS:

Q-1 Explain the phenomenon of arc formation .[2016(s),2017(s)]

Q-2 Explain plain break oil circuit-breaker. [2016(s),2017(s)]

With neat sketch expain costruction and operating details of VCB [2019(S)]

Discuss the constructional details and operation of a typical low oil circuit breaker ?
[2019(s),2014(S),2015(S)]

Explain low resistance method of Arc extinction ? [2019 (s)]

Write short notes on SF₆ circuit breaker [2016(s),2017(s).2018(s)]

With neat sketch explain about restriking and recovery voltage [2014(s),2018
(W)]

Explain high resistance method of Arc extinction .[2019 (s)]Q-9

Explain rating of circuit breaker [2014(s).

Q-10 Discuss the arc phenomenon and various methods of arc extinction in a circuit breaker .[2018(s)]

END

PROTECTIVE RELAYS

Definition of protective relay: A protective relay is a device that detects the fault and initiates the operation of the circuit breaker to isolate the defective system.

Fundamental requirement of protective relay: The following are the main function of the protective relay:

Selectivity: It is the ability of the protective system to select correctly that part of the system in trouble and disconnect the faulty part without disturbing the rest of the system.

Speed: The relay system should disconnect the faulty section as fast as possible.

Sensitivity: It is the ability of the system to operate with low value of actuating quantity.

Reliability: It is the ability of the relay system to operate under the pre-determined conditions.

Simplicity: The relaying system should be simple so that it can be easily maintained.

Economy: The protective relay system is must be in low cost.

Fault clearing process/Basic relay operation of relay:

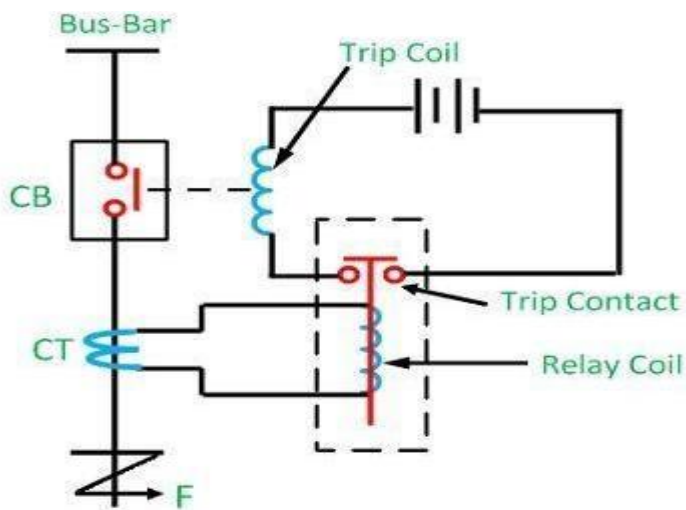

Basic Connection Diagram of Protective Relay

Circuit Globe

A simple relay circuit is shown in above diagram. The relay circuit connection is divided into three parts:

- First part is the primary winding of a current transformer (C.T) which is connected in series with the line to be protected.
- Second part consists of secondary winding of CT and relay operating coil .

- Third part is the tripping circuit which may be either ac or dc .It consists of a source of supply ,the trip coil of the circuit breaker and relay stationary contact.

When a short circuit occurs at point F on the transmission line ,the current flowing on the line increases to an enormous value .This result in a heavy current flow through the relay coil ,causing the relay to operate by closing its contacts .This is in turn closes the trip circuit of the breaker,making the circuit breaker open and isolating the faulty section from the rest of the system.

Basic relay operation: The basic relays are work on the following two main operating principle:

- Electromagnetic attraction type:
- Electromagnetic induction type:

Electromagnetic attraction type:

- Electromagnetic attraction relays operate on the principle of an armature being attracted to the poles of an electromagnet .
- This relays may be actuated by dc or ac quantities.

The important types of electromagnetic attraction relays are :

- Attracted armature type relay
- Solenoid type relay
- Balanced beam type relay

Attracted armature type relay:

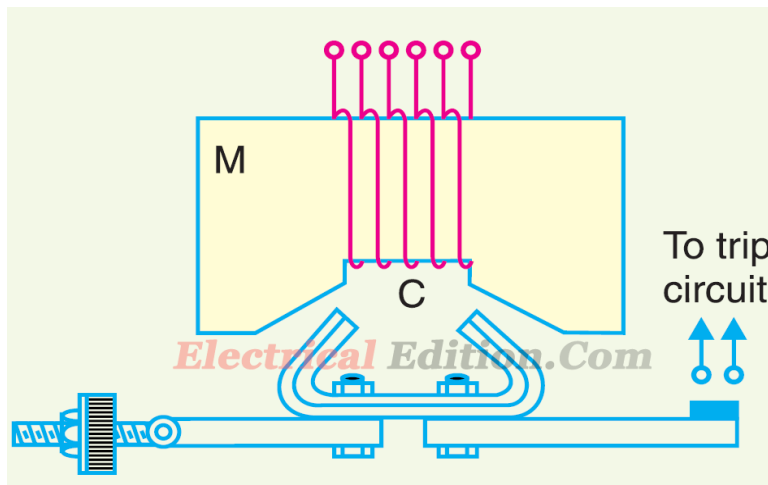

- It consists of a laminated electromagnet M carrying a coil C and a pivoted laminated armature.
- Under normal condition the current through the relay coil C is such that counter weight holds the armature in the position.
- Under fault condition , the relay armature is attracted upwards and this completes the trip circuit which results in the opening of the circuit breaker.

Solenoid type relay:

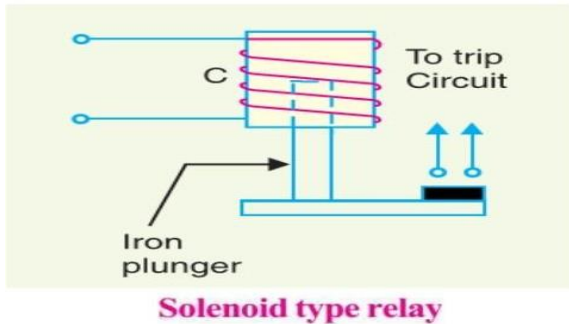

- It consists of a solenoid and movable iron plunger.
- Under normal operating condition, the current through the relay coil C is such that it holds the plunger in the position shown.
- Under fault condition, the plunger is moved upward and closes the trip circuit, thus opening the circuit breaker.

Balanced beam type relay:

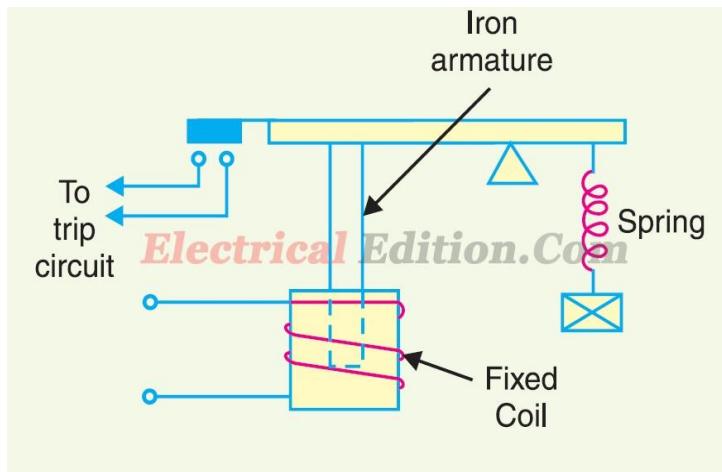

- It consists of an iron armature fixed to a balanced beam.
- Under normal operating condition, the current through the relay coil is such that the beam is held in the horizontal position by the spring.
- Under fault condition the beam is attracted to close the trip circuit thus opening the circuit breaker.

Induction relay :

Electromagnetic induction relays operate on the principle of mutual induction.

This relay operates on the AC quantities.

An induction relay can consist of a pivoted aluminium disc placed in the magnetic field.

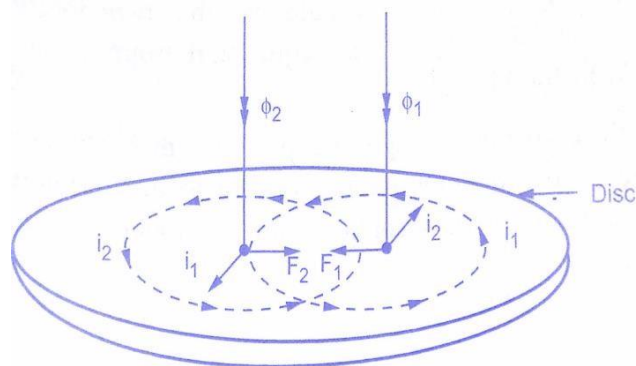

From above fig,

$$\phi_1 = \phi_{1\max} \sin \omega t$$

$$\phi_2 = \phi_{2\max} \sin(\omega t + \alpha)$$

We know from Faraday's laws of electromagnetic induction

$$i_1 \propto \frac{d\phi_1}{dt} \propto \frac{d}{dt} (\phi_{1\max} \sin \omega t)$$

$$i_2 \propto \phi_{1\max} \cos \omega t$$

$$\text{and } i_2 \propto \phi_{2\max} (\cos \omega t + \alpha)$$

$$\therefore F_1 \propto \phi_1 i_2 \text{ and } F_2 \propto \phi_2 i_1$$

Hence net force F at the instant is ,

$$F \propto F_2 - F_1$$

$$\propto \phi_2 i_1 - \phi_1 i_2$$

$$\propto \phi_{2\max} \sin(\omega t + \alpha) \phi_{1\max} \cos \omega t - \phi_{1\max} \sin \omega t \phi_{2\max} \cos(\omega t + \alpha)$$

$$\propto \phi_{1\max} \phi_{2\max} [\sin(\omega t + \alpha) \cos \omega t - \sin \omega t \cos(\omega t + \alpha)]$$

$$\propto \phi_{1\max} \phi_{2\max} \sin \alpha$$

$$\propto \phi_1 \phi_2 \sin \alpha \text{ ----- (1)}$$

$$F \propto \phi_1 \phi_2 \sin \alpha$$

The following three types of structure are commonly used for obtaining the phase difference in the fluxes and the operating torque in induction relays.

- Shaded pole structure
- Watt hour meter or double winding structure
- Induction cup structure

Shaded pole structure:

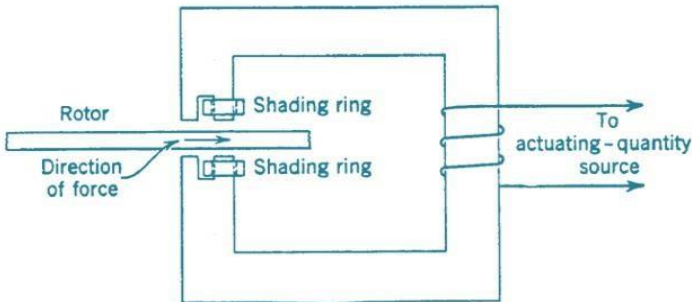

- It consists of a pivoted disc free to rotate in the air gap of an electromagnet .
- One half of each pole of the magnet is surrounded by a copper band known as shading ring.
- The alternating flux ϕ_s in the shaded portion of the pole will, owing to the reaction of the current induced in the ring , lag behind the flux ϕ_μ in the unshaded portion by an angle α .
- These two ac fluxes differing in phase will produce the necessary torque to rotate the disc .
- The driving torque T is given by, $T \propto \phi_s \phi_\mu \sin \alpha$.
- Assuming the fluxes ϕ_s and ϕ_μ to be proportional to the current I in the relay coil, $T \propto I^2 \sin \alpha$. This shows the driving torque is proportional to the square of current in the relay coil.

Watt-hour-meter structure :

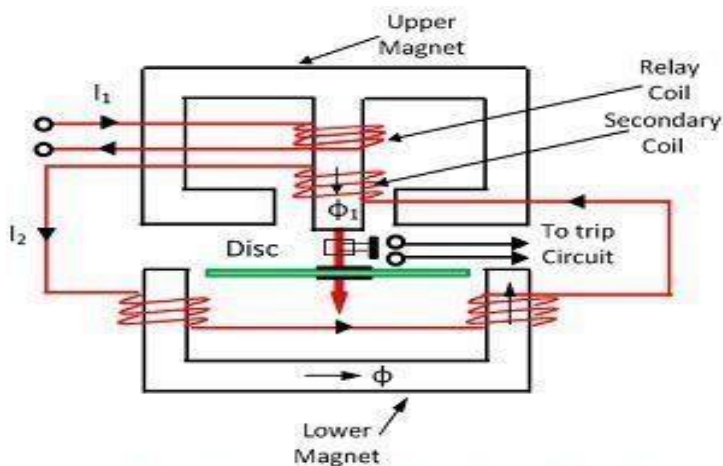

Watt-hour Meter Type Induction Disc Relay

Circuit Globe

- It consists two magnets two magnets one is lower magnet another is upper magnet.
- Upper magnet consists of primary winding and secondary winding.
- A pivoted aluminium disc arranged to rotate freely between the poles of two electromagnets .

- The primary winding carries relay current I_1 while the secondary winding is connected to the winding of the lower magnet .
- The primary current induces emf in the secondary and so circulates the current I_2 in it.
- The flux ϕ_2 induced in the lower magnet by the current in the secondary winding of the upper magnet will lag behind ϕ_1 by an angle α .
- The two fluxes ϕ_1 and ϕ_2 differing in phase by α will produce a driving torque on the disc proportional to $\phi_1 \phi_2 \sin\alpha$.

Induction cup structure:

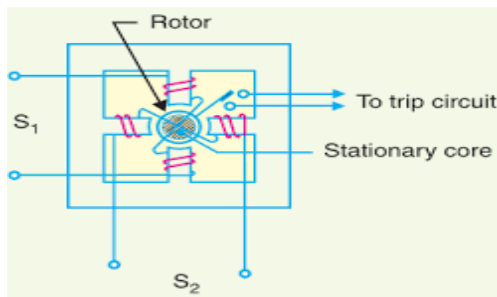

- It most closely resembles an induction motor , except that the rotor iron is stationary ,only the rotor conductor portion being free to rotate.
- The moving element is a hollow cylindrical rotor which turns on its axis .
- The rotating field is produced by two pairs of coils wound on four poles as shown.
- The rotating field induces current in the cup to provide the necessary driving torque.

Definition of following important terms:

Pick-up current: It is the minimum current in the relay coil at which the relay starts to operate .

Current setting: The adjustment of the pick-up current to any required value is known as current setting.

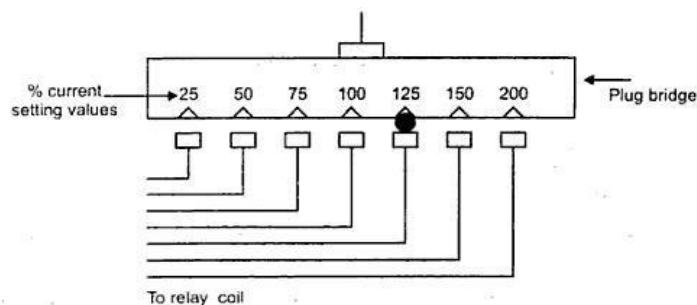

Example: Suppose that an overcurrent relay having current setting of 125% is connected to supply circuit through a CT of 400/5. Find pick-up current.

Ans: Pick-up current = $5 \times 1.25 = 6.25$ A.

Plug-setting multiplier (PSM): It is the ratio of fault current in relay coil to the pick-up current.

$$\text{PSM} = \frac{\text{Fault current in relay coil}}{\text{Pick-up current}}$$

$$= \frac{\text{Fault current in relay coil}}{\text{Rated secondary current of CT} \times \text{current setting}}$$

Example: Suppose that a relay is connected to a 400/5 CT and set of 150 % ,with a primary fault current of 2400 A. Find PSM.

Solution: Pick-up current = Rated secondary current of CT \times current setting = $5 \times 1.5 = 7.5$ A

Fault current in relay coil = $2400 \times (5/400) = 30$ A .

plug setting multiplier = $30/7.5 = 4$.

Time setting multiplier: The adjustment of control of time operation in the relay is known as time setting multiplier.

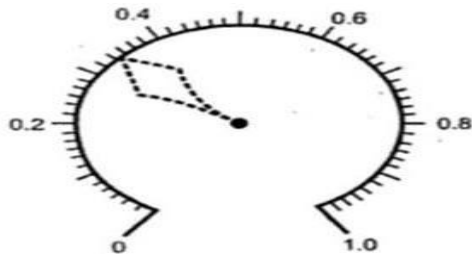

Example: In an over current relay the time setting is 0.1 and time obtained from the time/PSM curve in 3 sec. Find the actual relay operating time.

Solution: Actual relay operating time = $3 \times 0.1 = 0.3$ sec.

Time/PSM curve: The curve between time of operation and plug setting multiplier of a typical relay is known as Time/PSM curve.



Example: Determine the time of a 5-ampere ,3-second overcurrent relay having a current of 125 % and a time setting multiplier of 0.6 connected to supply circuit through a 400/5 current transformer when the circuit carries a fault current of 4000 A .Use the curve as shown in fig .

Solution: Rated secondary current of CT = 5 A.

$$\text{Pick-up current} = 5 \times 1.25 = 6.25 \text{ A}$$

$$\text{Fault current in relay coil} = 4000 \times (5/400) = 50 \text{ A}$$

$$\therefore \text{ Plug-setting multiplier (PSM)} = 50/6.25 = 8$$

Corresponding to the plug-setting multiplier of 8 (See fig) , the time of operation is 3.5 seconds.

$$\therefore \text{ Actual relay operating time} = 3.5 \times \text{Time- setting} = 3.5 \times 0.6 = 2.1 \text{ seconds.}$$

Classification of functional relays: According to the function of power system relays are following types :

- Induction type overcurrent relays.
- Induction type reverse power relays.
- Distance relays.
- Differential relays.
- Translay scheme.

Induction type overcurrent relay (non-directional) :

Construction:

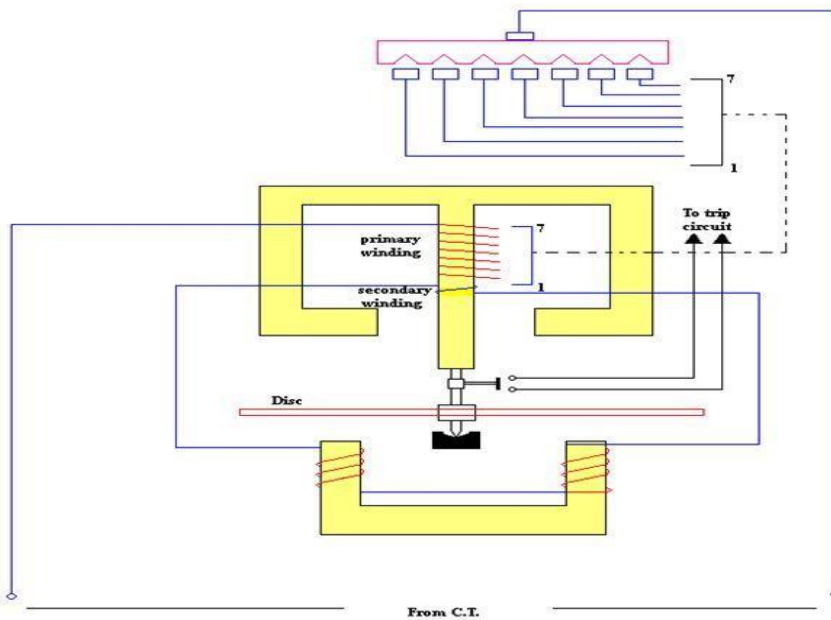

- This relay works on the principle of mutual induction.

- The actuating source is a fault current.
- It has two electromagnet called as upper and lower electromagnet.
- Upper electromagnet has a primary and secondary winding.
- Secondary winding is connected series with the lower electromagnet winding.
- Tapping are provided on the primary winding which are connected to a plug-bridge or plug-setting and CT.
- A metallic (aluminium) disc which is free to rotate in between the poles of two electromagnet.
- Time-setting is provided by adjusting the moving contact of disc.
- The controlling torque is provided by a spiral spring.

Operation:

- Under normal operating conditions ,restraining torque is greater than the driving torque produced by the relay coil current. Therefore the aluminum disc remains stationary .
- When fault occurs ,the current in the protected circuits exceeds the pre-set value ,the driving torque become greater then restraining torque.
- Hence the disc rotate and the moving contact bridges the fixed contacts.
- After that the trip circuit operates the circuit breaker.

Induction type directional power relay:

Construction:

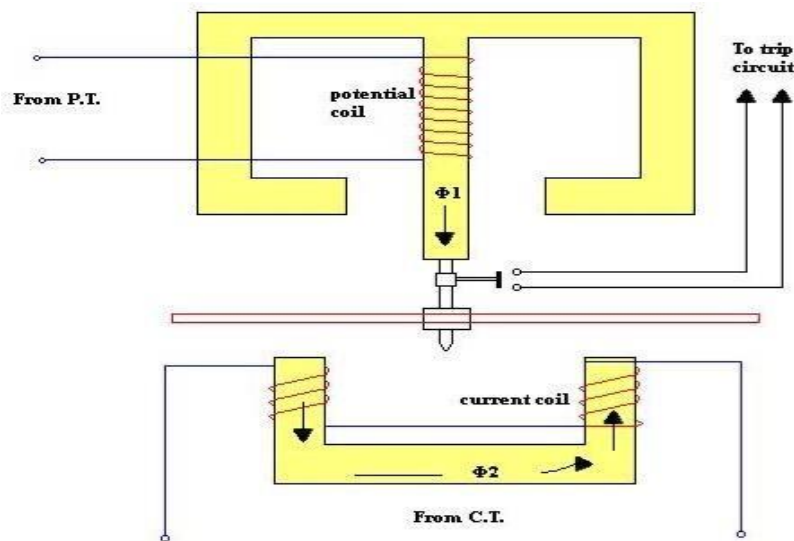

- It works on the principle of mutual induction .
- It consists of two electromagnet called as upper and lower electromagnet .
- Upper electromagnet's winding energised through a PT (called potential coil).
- Lower electromagnet's winding energised through a CT (called current coil).
- It consists of a aluminium disc free to rotate in between two poles of electromagnet.
- The tappings are provided on CC ,which are connected to plug-setting bridge.

Operation:

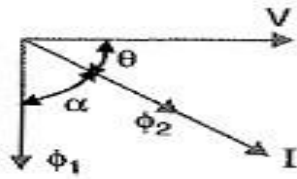

From vector diagram ,we see that

$$T \propto VI \sin (90^\circ - \theta)$$

$$T \propto VI \cos \theta$$

α power in the circuit

- Under normal condition ,the power will flow in the normal direction and the aluminium disc remain stationary .
- In abnormal condition ,the disc rotates and the moving contact closes the trip circuit.
- This causes the operation of circuit breaker which disconnect the faulty section.

Induction type direction overcurrent relay:

Construction :

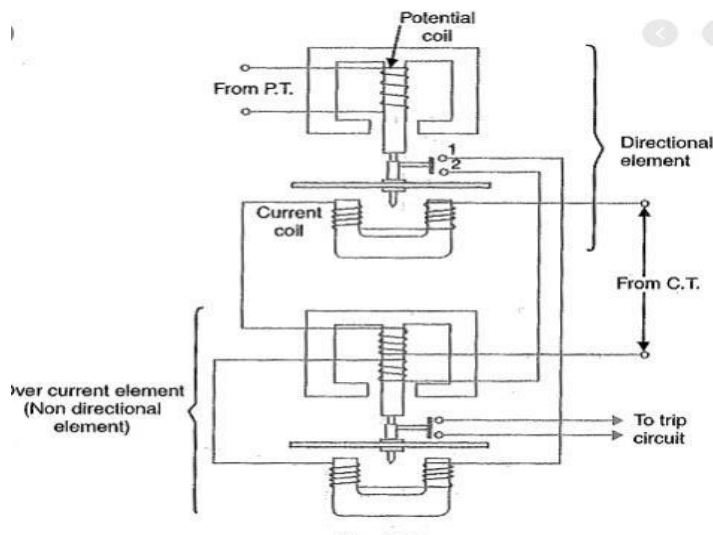

- It consists of two relay elements mounted on a common case viz (i) directional element and (ii) non-directional element.
- The directional element consists of upper and lower electromagnet of aluminium disc.
- The directional element energised from PT and CT.
- The non-directional element consists of upper magnet (primary winding and secondary winding), lower magnet and an aluminium disc.
- The non-directional element energised from CT and the trip contact of directional element.
- The non-directional element's aluminium disc trip contact connected to trip circuit.
- The tapping of current setting provided on non-directional elements primary windings.

Operation:

- Under normal condition the two aluminium disc remain stationary.
- When fault occurs the trip contact of directional element closes the circuit of lower magnet's winding of non-directional element .
- After that aluminium disc of non-directional element trip the circuit and hence operate the circuit breaker which isolate the faulty section.

Differential relays: A differential relay is one that operates when the phasor difference of two or more similar electrical quantities exceeds a pre-determined value .

There are two fundamental systems of differential or balanced protection.

- Current balance protection
- Voltage balance protection

Current differential relay :

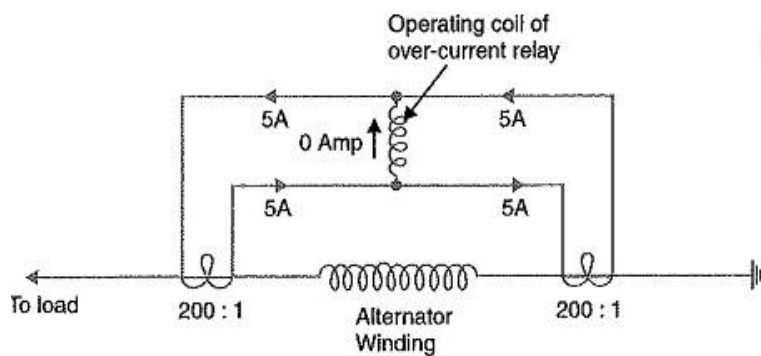

- A pair of identical current transformers are fitted on either end of the section to be protected.
- The secondary of CT's are connected in series in such a way that they carry induced currents in the same direction.
- The operating coil of the overcurrent relay is connected across the CT secondary circuit.

Operation:

- Under normal operating conditions , suppose the alternator winding carries a normal current of 1000 A. Then the currents in the two secondaries are equal. These currents will circulate between the two CT's and no current will flow through the differential relay.
 - If a ground fault occurs on the alternator winding, the two secondary currents will not be equal and the current flows through the operating coil of the relay causing the relay to operate.
- I. If some current (500A in this case) flows out of one side while a larger current (2000A) enters the other side as shown in below , then the difference of CT secondary currents i.e $10 - 2.5 = 7.5$ A will flow through the relay coil .

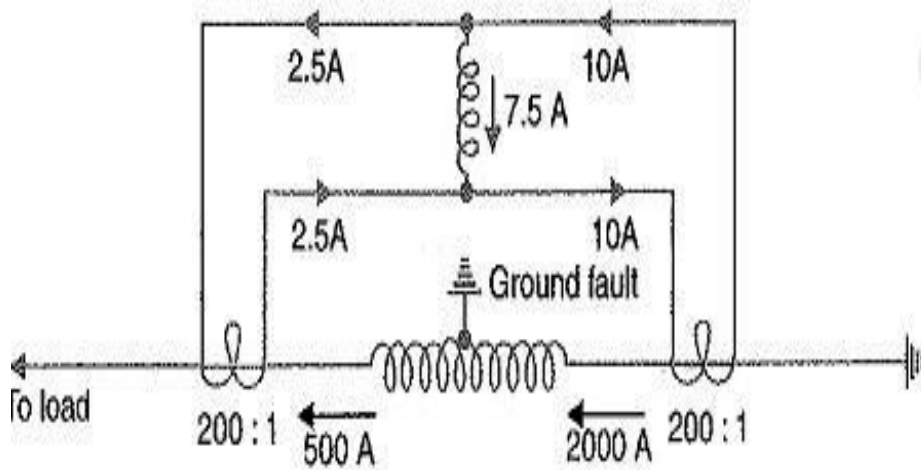

- II. If current flows to the fault from both sides as shown in below diagram, then the sum of CT secondary currents i.e $10 + 5 = 15$ A will flow through the relay.

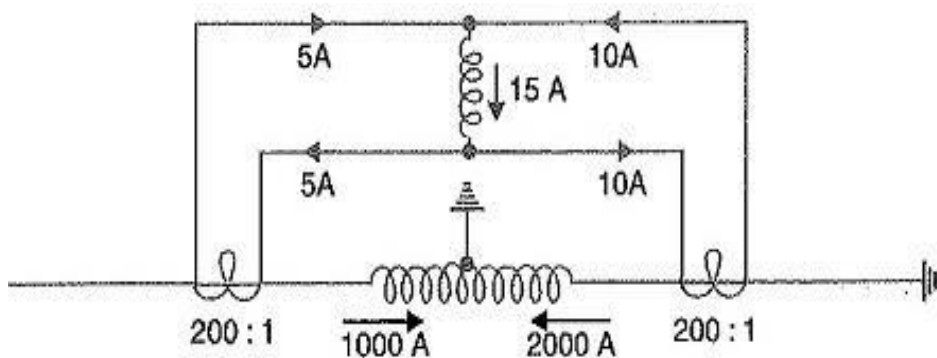

Disadvantages:

Pilot capacitance causes incorrect operation of the relay when a large current flows.

Accurate matching of CT's cannot be achieved due to pilot circuit impedance.

Voltage balance differential relay:

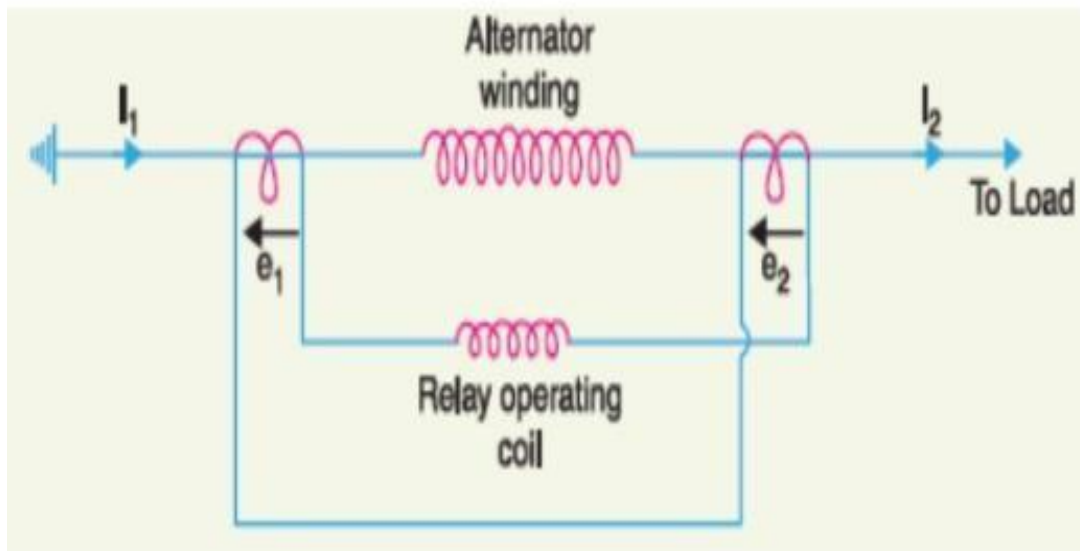

- In this scheme of protection two similar current transformers are connected at either end of the element to be protected (e.g an alternator winding) by means of pilot wires.
- The secondaries of current transformers are connected in series with relay in such a way that under normal conditions ,their induced emfs are in opposition .

Operation:

- Under healthy conditions equal currents ($I_1=I_2$) flow in both primary windings.
- Therefore the secondary voltages of two transformers are balanced against each other and no current will flow through the relay operating coil.
- When fault occurs in the protected zone ,the current in the two primaries will differ from ($I_1 \neq I_2$) and their secondary voltages no longer be in balance.
- This voltage difference will cause a current to flow through the operating coil of the relay which close the trip circuit .

Disadvantages:

- A multigap transformer construction is required to achieve the accurate balance between current transformer pairs.
- The system is suitable for protection of cables of relatively short length due to capacitance of pilot wires.
- On long cables , the charging current may be sufficient to operate the relay even if a perfect balance of current transformer is attained.

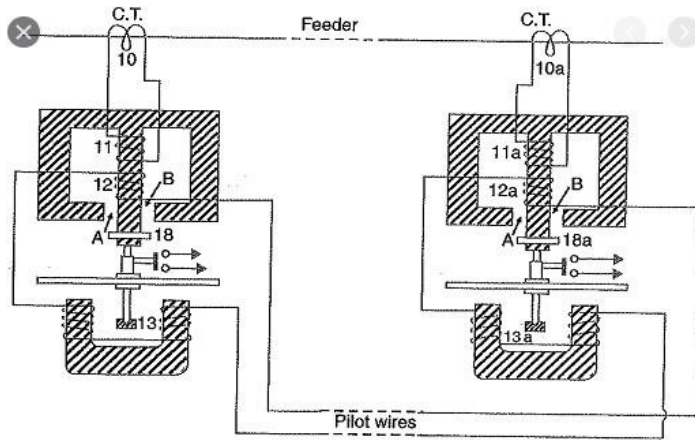
Traslay system:**Construational details:**

- It consists of two identical double winding induction type relays fitted at either end of the feeder to be protected.
- The primary circuits(11,11a) of these relays are supplied through a pair of current transformers.
- The secondary windings (12,13 and 12a,13a) of the two relays are connected in series by pilot wires in such a way that voltages induced in the former opposes the other.
- The compensating devices (18,18a) neutralize the effects of pilot-wire capacitance currents.

Operation:

- Under healthy conditions ,the current at the two ends of the protected feeder is the same and the primary windings (11,11a) of the relays carry the same current.
- The windings 11 and 11a induce equal emfs in the secondary windings 12,12a and 13,13a.
- As these windings are so connected that their induce voltages are in opposition ,no current will flow through the pilots or operating coils and hence no torque will be exerted on the disc either relay.
- When fault occurs ,on the protected feeder ,current leaving the feeder will differ from the current entering the feeder.
- Consequently unequal voltages will be induced in the secondary windings of the relays and current will circulate between the two windings ,causing the torque to be exerted on the disc of each relay.
- As the direction of the secondary current will be tend to close the trip circuit while the other relay ,the torque will hold the movement in the normal unoperated position.
- Closed copper rings (18.18a) in neutralizing the effects of pilot capacitive currents.

Types of protection: Protection schemes are two types :

- Primary protection
- Back-up protection

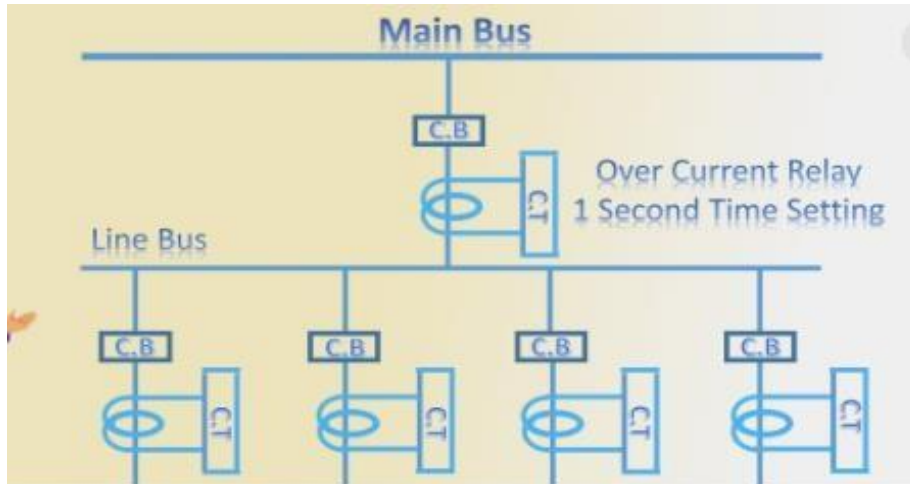

Primary protection:

- It is the protection scheme which is designed to protect the component parts of the power system.
- In above figure each line has an overcurrent relay that protects the line .
- If fault occurs on any line ,it will be cleared by its relay and circuit breaker .
- This forms the primary or main protection and serves as the first line of defence

Back-up protection:

- It is the second line of defence in case of failure of the primary protection.
- It is designed to operate with sufficient time delay so that primary relaying will be given enough time to function if it is able to .
- In above figure relay A provides back-up protection for each of four lines.
- If a line fault is not cleared by its relay and breaker ,the relay A on the group breaker will operate after a definite time delay and clear entire group of lines.

Short questions with answer:

Q-1 Define PSM .[2005(W),2009(S),2012(S),2015(S),2016(S),2017(S),2018(S),2019(S)]

ANS: It is the ratio of fault current in relay coil to the pick-up current.

$$\text{PSM} = \frac{\text{Fault current in relay coil}}{\text{Pick-up current}}$$

$$= \frac{\text{Fault current in relay coil}}{\text{Rated secondary current of CT} \times \text{current setting}}$$

Q-2 What is pick-up current ? [2015(S),2018(S),2019(S)]

ANS: It is the minimum current in the relay coil at which the relay starts to operate .

Q-3 Define TSM .[2018(S)]

ANS: The adjustment of control of time operation in the relay is known as time setting multiplier.

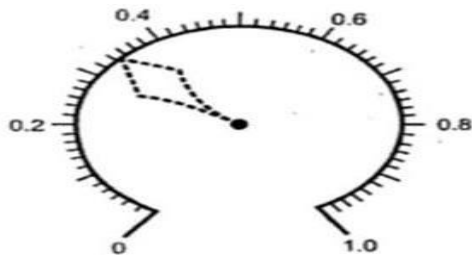

Long questions :

Explain current differential relay.[2016(S),2017(S)]

Explain basic operation of induction relay. [2015(S),2016(S),2017(S)]Q-3

Explain essential quality of good protective relay [2014(S)]

Write short note on electromagnetic attraction relay .[2018(S)]

Describe the construction and principle of an induction type directional overcurrent relay [2019(S)]

END

PROTECTION OF ELECTRICAL POWER EQUIPMENT AND LINES

Protection of alternator: There are some important faults occur on an alternator are follows below:

- Failure of prime-mover
- Failure of field
- Overcurrent
- Over voltage
- Unbalanced loading
- Stator windings faults

Failure of prime-mover:

- The failure of prime-mover in an alternator mechanically coupled to turbine.
- Primemover failure occurs ,the machine can safely isolated by the control room attendant.
- Therefore the automatic and electrical protection is not required.

Failure of field:

- The chance of field failure of alternator are undoubtedly very rare.
- If field failure occur , then alternator can run for a short period .
- This short period allowed control room attendant to disconnect the faulty alternator manually from the system bus-bars.

Over-current:

- The overcurrent occurs on an alternator due to over load on the supply system and partial breakdown of winding insulation.
- For protection of alternator from overcurrent ,the m/c should be designed with high values of internal impedance and can be disconnect manually.

Over speed:

- The chief cause of over speed is the sudden loss of all or the major part of load on the alternator
- Modern alternator are usually provided with mechanical centrifugal devices mounted on their driving shafts to trip the main valve of the prime mover when a dangerous over speed occurs.

Over voltage:

- Over voltage in an alternator occurs when the speed of the prime mover increases due to sudden loss of the alternator load.
- Control governors (system turbine)exercise a continuous check on over speed and thus prevent the occurrence of over voltage on generating unit.

Unbalanced loading:

- Unbalanced loading means that there are different phase currents in the alternator.
- Unbalanced loading arises from faults to earth or faults between phases on the circuit external to the alternator.
- The circuit diagram below shows the protection of alternator against unbalanced loading.

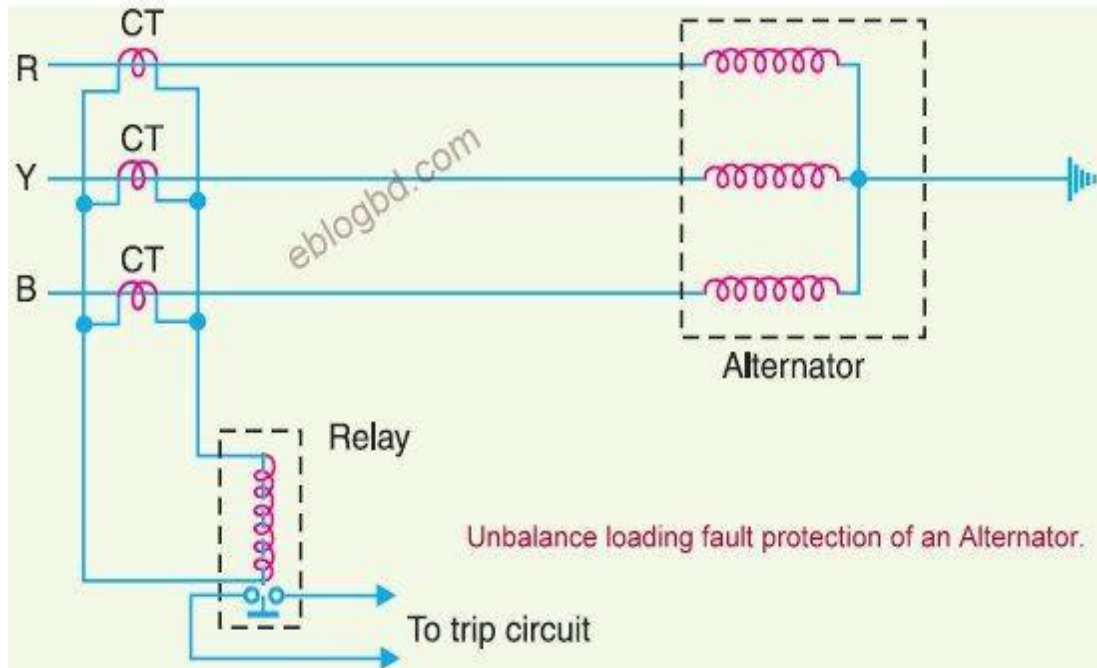

- Three current transformers, one mounted on each phase having their secondaries connected in parallel.
- A relay is connected in parallel across the transformer secondaries.
- Under the normal operating conditions, equal current flow through the different phases of the alternator and their algebraic sum is zero.
- Therefore the sum of current flowing in the secondaries is also zero and no current flows through the operating coil of the relay.
- However if unbalancing occurs, the currents induced in the secondaries will be different and the resultant of the currents will flow through the relay.
- The operation of the relay trip the circuit breaker to disconnect the alternator from the system.

Stator winding faults:

- These faults occurred mainly due to the insulation failure of the stator windings.
- The main types of stator winding faults are:
 - Fault between phase and ground.
 - Fault between phases.
 - Inter-turn fault involving turns of the same phase windings.

- For protection of alternator against such above faults differential method of protection (also known as Merz-Prize System) is employed.

Differential protection of alternators (Merz-Prize circulating current scheme):

Schematic arrangement:

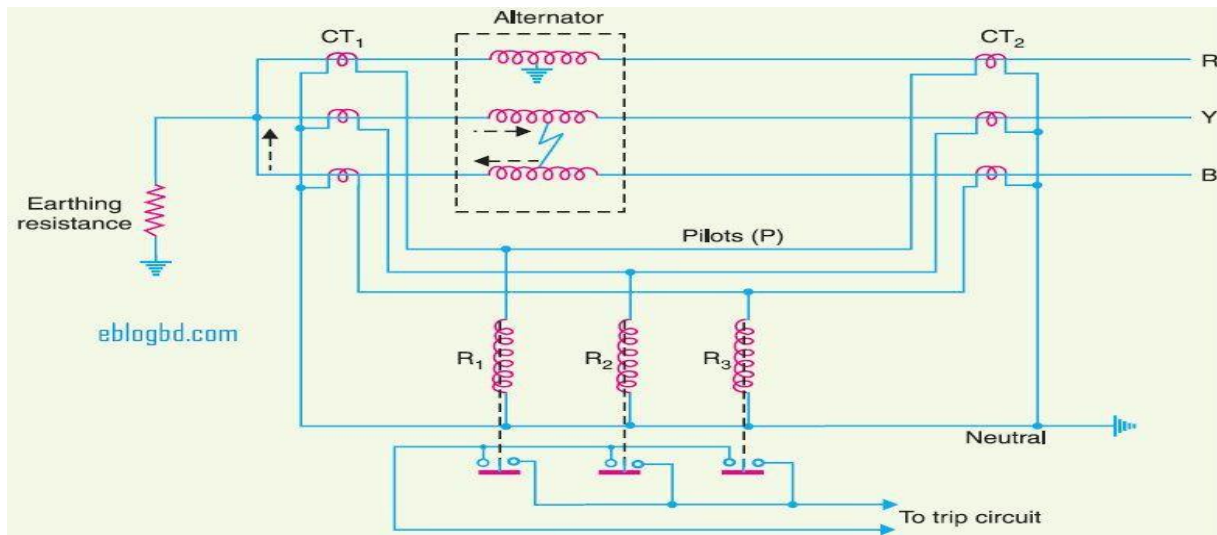

- Above figure shows the schematic arrangement of current differential protection for a 3- ϕ alternator.
- Identical current transformer pairs CT_1 and CT_2 are placed either side of each phase of the stator windings.
- The secondaries of each set of current transformers are connected in star.
- There is two star groups i.e is stator winding and CT secondaries.Hence there is two neutral points.
- The terminals of two star groups being connected together by means of a four core pilot cable.

Operation:

The above circuit diagram can be redrawn in the simple form as follow below:

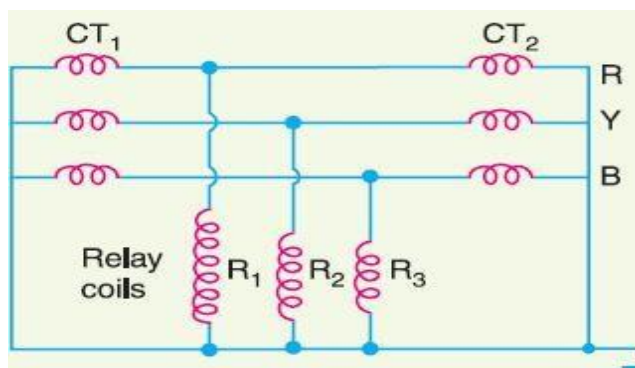

- Under normal operating conditions, the current at both ends of each winding will be equal.
- Hence the currents in the secondaries of the two CTs are connected in any phase will also be equal.
- Therefore, there is balanced circulating current in the pilot wires and no current flows through the operating coils (R_1, R_2 and R_3) of the relays.
- When an earth fault or phase-to-phase fault occurs, this condition no longer holds good and the differential current flowing through the relay circuit operates the relay to trip the circuit breaker.

Balanced earth fault protection:

Schematic arrangement:

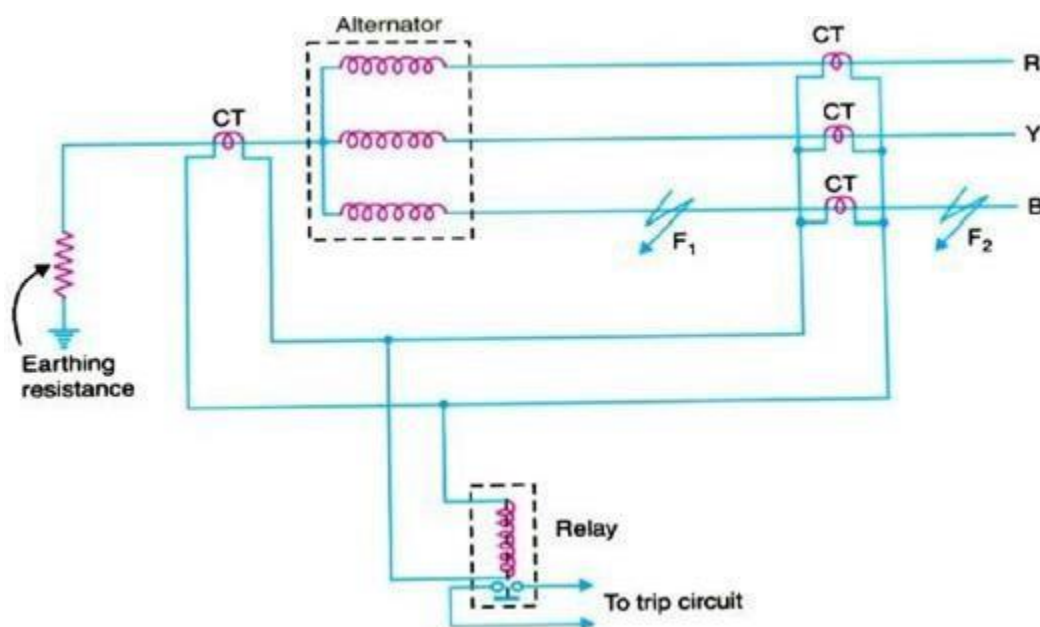

- It consists of three line current transformers, one mounted in each phase.
- Another CT connected in the star point of the alternator to each.
- The secondaries of three current transformers are connected in parallel with that of a single current transformer.
- A relay is connected across the transformers secondaries.

Operation:

- Under normal conditions, equal currents flow through the different phases of the alternator and their algebraic sum is zero.
- Therefore the sum of currents flowing in the secondaries is also zero and no current flow through the operating coil of the relay.
- Under these conditions, the current in the neutral wire is zero and the secondary of neutral current transformer supplies no current to the relay.

- If an earth fault develops at F_2 external to the protected zone, the sum of the currents at the terminals of the alternator is exactly equal to the current in the neutral connections and hence current flows through the relay.
- When an earth fault occurs at F_1 or within the protected zone, these currents are no longer equal and the currents flows through the relay to operate the circuit breaker.

Protection systems for Transformers: The common transformer faults are :

- Open circuits
- Over heating
- Winding short-circuits e.g earth-faults, phase to phase faults and inter turn faults.

The principal relays and systems used for transformer protection are :

- Buchholz devices providing protection against all kind of incipient faults such as insulation failure of windings, core heating , fall of oil level due to leakage joints etc.
- Earth faults relays providing protection against earth-fault only.
- Over current relays protection mainly against phase-to-phase faults and over loading.
- Differential system (or circulating-current system) providing protection against both earth fault and phase faults.

Buchholz relay: Buchholz relay is a gas actuated relay installed in oil immersed transformers against all kinds of faults.

Diagram:

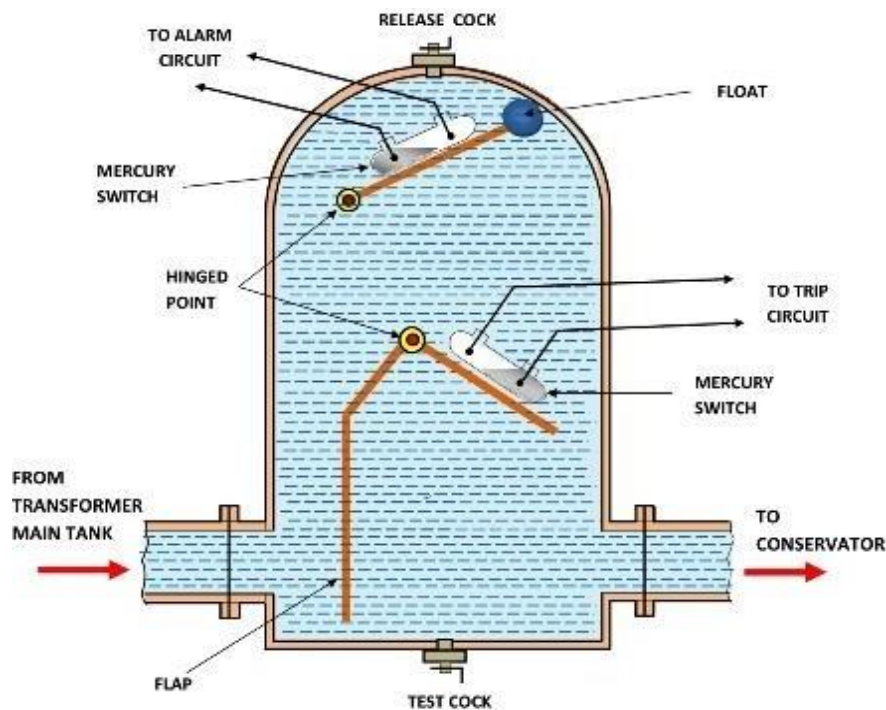

Construction:

- It takes the form of domed vessel placed in the connecting pipe between the main tank and conservator.
- The device has two elements i.e upper and lower.
- The upper element consists of a mercury type switch attached to a float.
- The lower element contains a mercury switch mounted on a hinged type flap located in the direct path of the flow of oil from transformer to the conservator.
- The upper element closes an alarm circuit during incipient faults.
- The lower element is arranged to trip the circuit breaker in case of severe faults.

Operation: The operation of Buchholz relay is as follows below:

- In case of incipient faults within the transformers the heat due to fault causes the decomposition of some transformer oil in the main tank. The product of decomposition contains more than 70 % of hydrogen gas being light tries to go into the conservator. At that moment the gas get deposited in the upper part of the relay chamber .When a high amount of gas gets accumulated ,it exerts sufficient pressure on the float to cause it to tilt and close the contacts of mercury switch attached to it. This completes the alarm circuit to sound on the alarm.
- If a serious fault occurs in the transformer, an enormous amount of gas is generated in the main tank. The oil in the main tank rushes towards the conservator through Buchholz relay and in doing so tilts the flap to close the contacts of mercury switch.This completes the trip circuit to open the circuit breaker controlling the transformer .

Advantages:

- It is simplest form of transformer protection.
- It detects the incipient faults at a stage much earlier than is possible with other forms of protection.

Disadvantages:

- It can only be used with oil immersed transformers equipped with conservator tank.

Earth-fault or leakage protection:

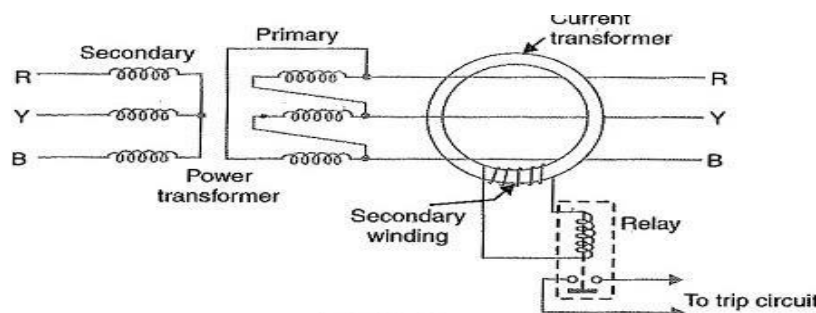

Operation:

- Under normal operating condition (i.e no fault current to earth),the vector sum of the three phase current is zero and there is no resultant flux in the core of the current transformer.
- Consequently no current flows through the relay and it remains in operative.
- When earth fault occurs the vector sum of three phase current is no longer zero.
- The resultant currents sets up flux in the core of the CT ,which induces emf in the secondary winding.
- This energies the relay to trip the circuit breaker and disconnect the faulty transformer from the system.

Circulating-current scheme for transformer protection:

Diagram:

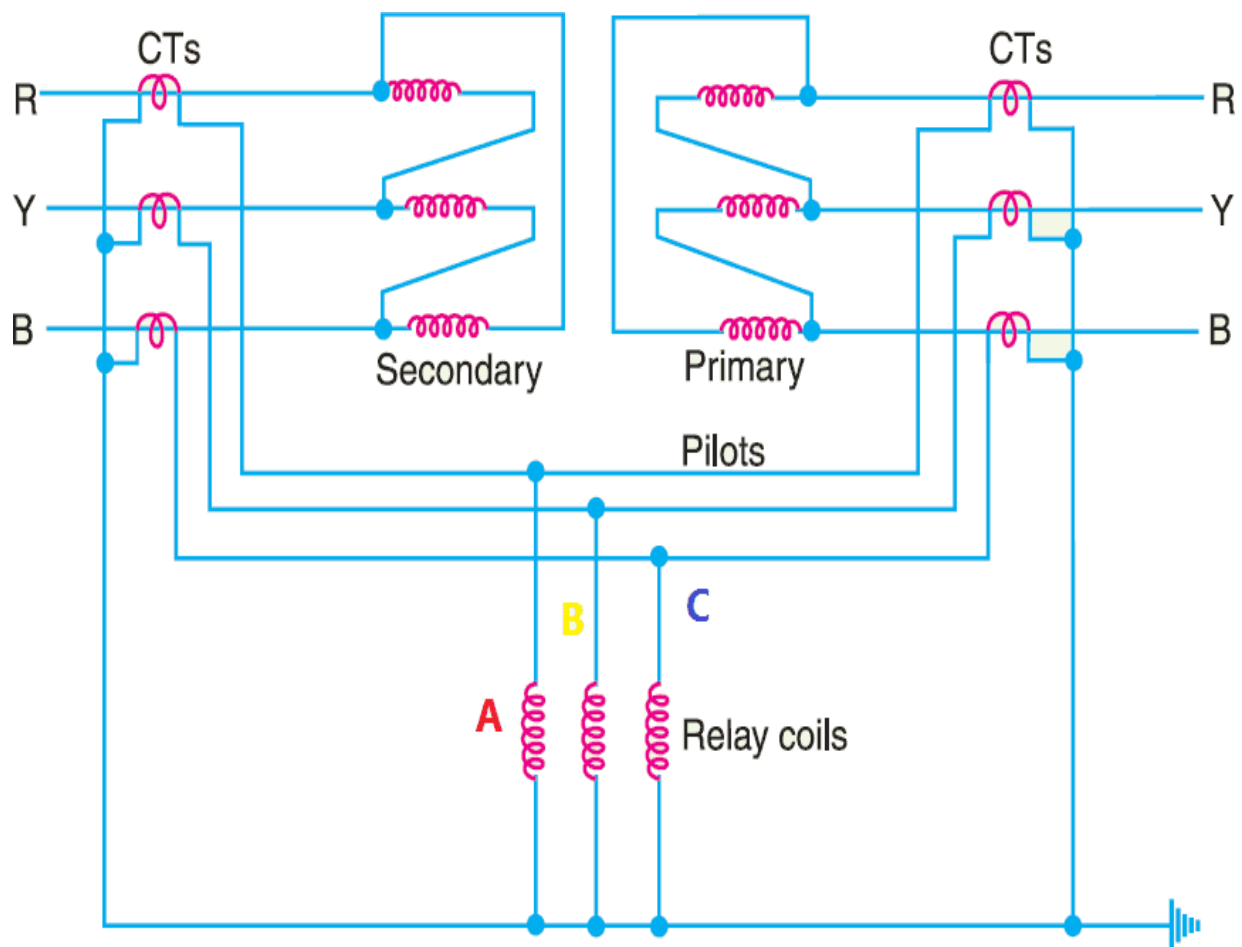

- In above diagram a 3 - \emptyset delta/delta power transformer connected.
- CTs on the two sides of the transformer are connected in star.
- The CTs on the two sides are connected by pilot wires and one relay is used for each pair of CTs.

Operation:

- Under normal operating conditions, the secondaries of CTs carry identical currents.
- Therefore , the currents entering and leaving the pilot wires of both ends are the same and no current flows through the relays.
- If a ground or phase to phase fault occurs ,the current in the secondaries of CTs will no longer be the same and the differential current flowing through the relay circuit will clear the breaker on both sides of the transformer.

Protection of bus bar: Bus-bars in the generating stations and substation form important link between the incoming and outgoing circuits.

The two most commonly used scheme for bus bar protection are :

- Differential protection
- Fault bus protection

Differential protection: The basic method for bus-bar protection is the differential scheme in which currents entering and leaving the bus are totalized.

Diagram:

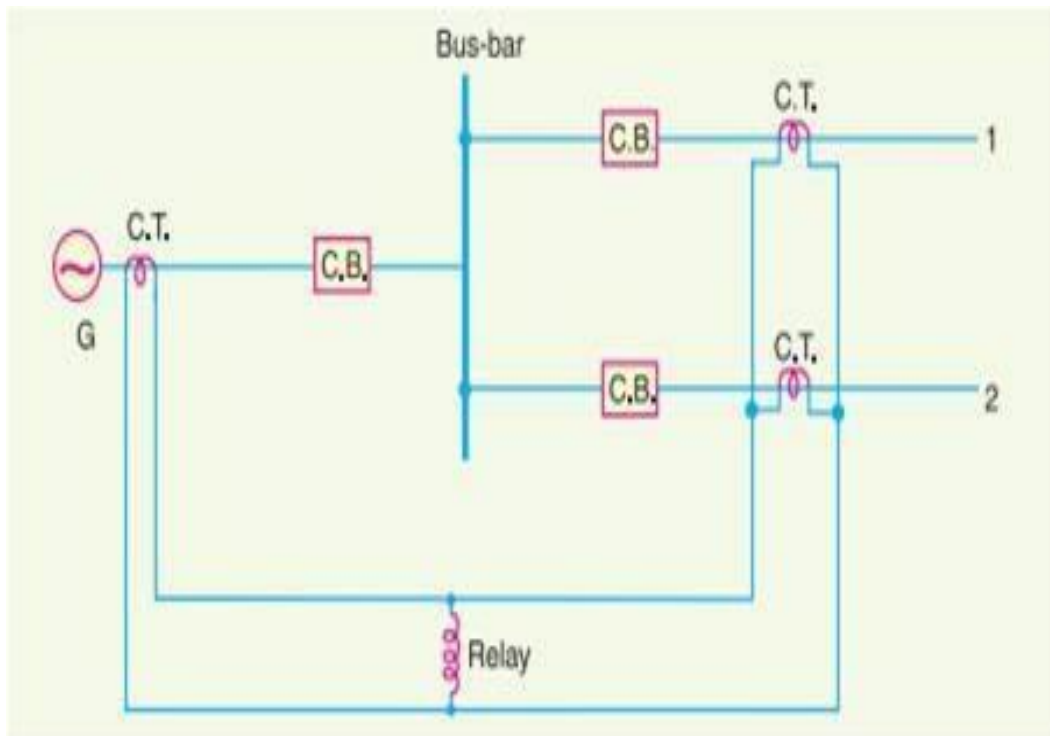

- During normal load condition , the sum of these currents is equal to zero.
- When a fault occurs , the fault current upsets the balance and produces a differential current to operate a relay.

Fault bus protection:

Schematic arrangement:

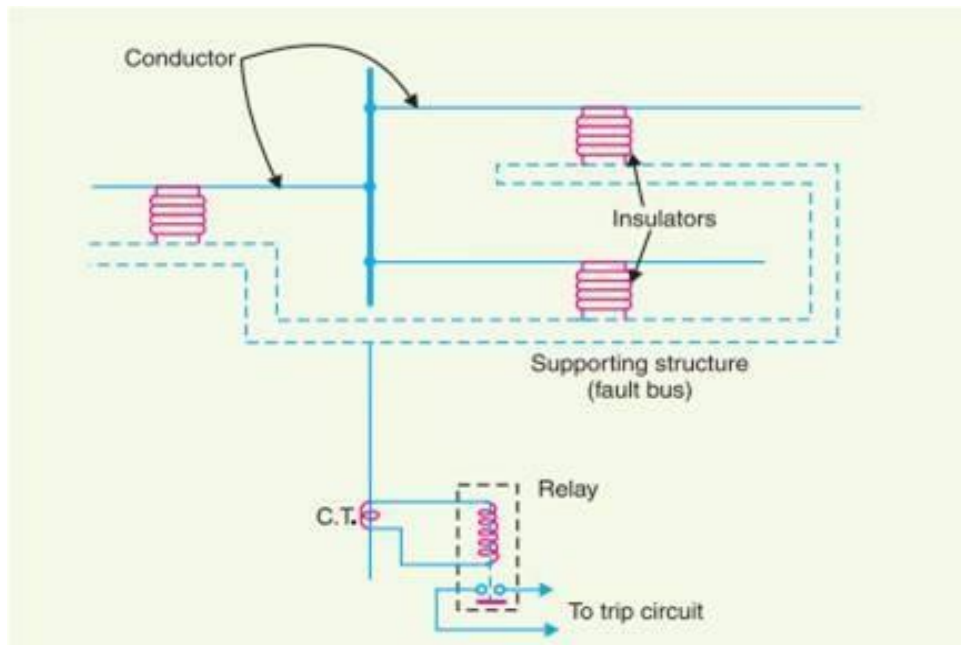

- The metal supporting structure or fault bus is earthed through a CT.
- A relay is connected across the secondary of this circuit.

Operation:

- Under normal operating conditions, there is no current flow from fault bus to ground and the relay remains inoperative.
- A fault involving a connection between a conductor and earth supporting structure will result in current flow to ground through the fault bus, causing the relay to operate.
- The operation of the relay will trip all breakers connecting equipment to the bus.

Protection of transmission lines: The common methods of line protection are:

- Time-graded overcurrent protection
- Differential protection
- Distance protection

Time graded over current protection:

- Here overcurrent non directional relays are used.
- The relays employed are operated under some definite time of operation.
- Time-graded overcurrent protection are three types:

- Radial feeder
- Parallel feeder
- Ring main system

Radial feeder:

- Here power can flow only in one direction from generator or supply end to the load .
- Time-graded protection of a radial feeder can be achieved by using :
 - Definite time relays
 - Inverse time relays
- Definite time relays:

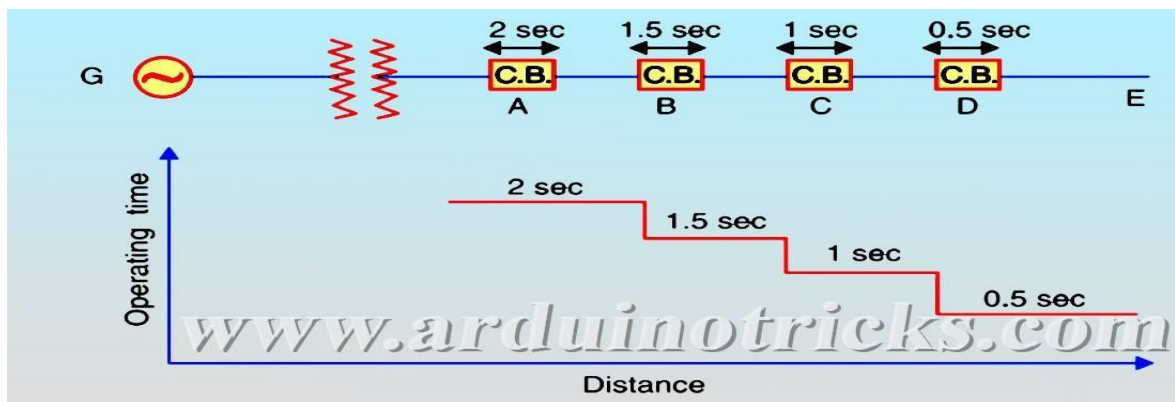

- Here non-directional overcurrent relays are used.
- Here all relays are set with definite time.
- If a fault occurs in the section DE, it will be cleared in 0.5 sec by the relay and circuit breaker at D because all other relays have higher operating time .
- Using inverse time relays:

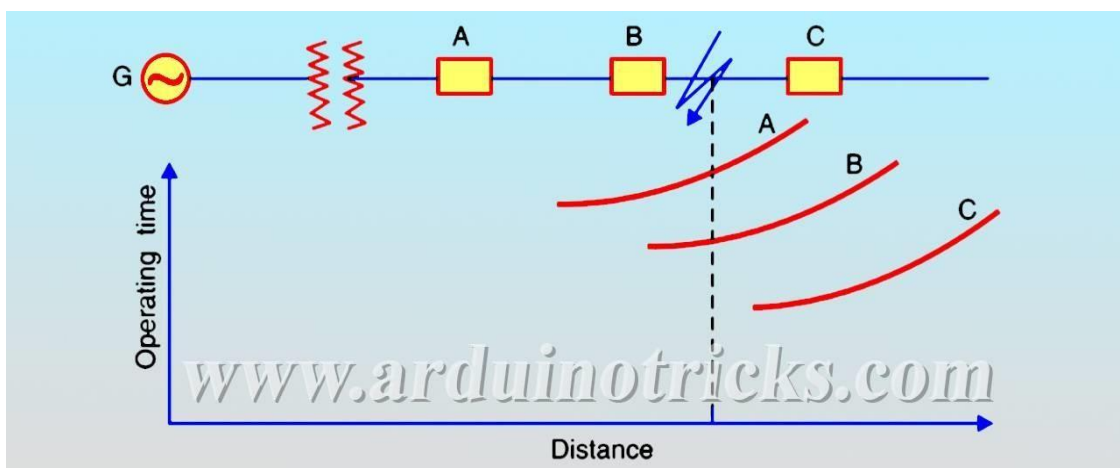

- Here also non-directional over-current relays are used.
- All relays operating time is inversely proportional to the operating current.

Parallel feeder:

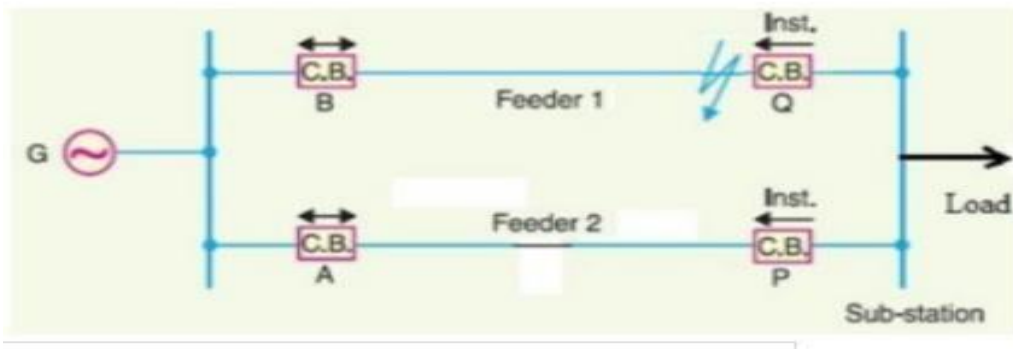

- Here non-directional and a reverse power or directional relay used.
- At generator end non-directional relay and at the substation end reverse power relay used.
- If fault occurs at feeder -1 only B and Q should isolate the faulty section.

Ring main system:

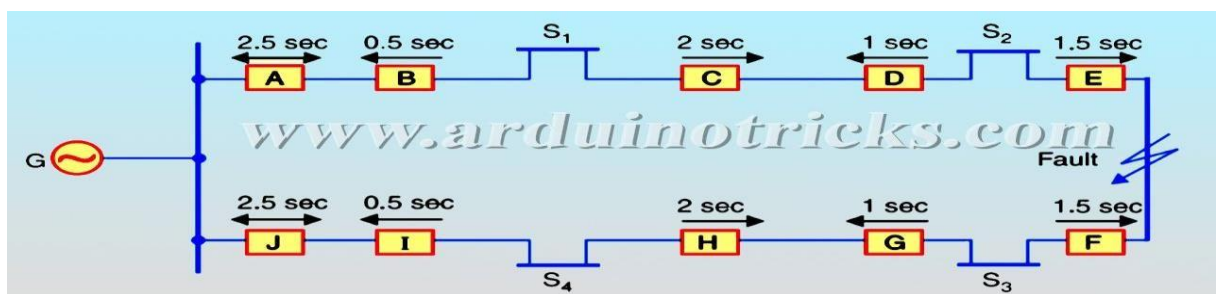

- In this system various power stations or substations are inter connected by alternate routes thus forming a closed ring.
- In case of damage to any section of the ring , that section may be disconnected for repairs and power will be supplied from both ends at the ring ,there by maintaining continuity of supply ‘
- If fault occurs on section EF then only E and F will operates because of their lower time setting.

Distance protection:

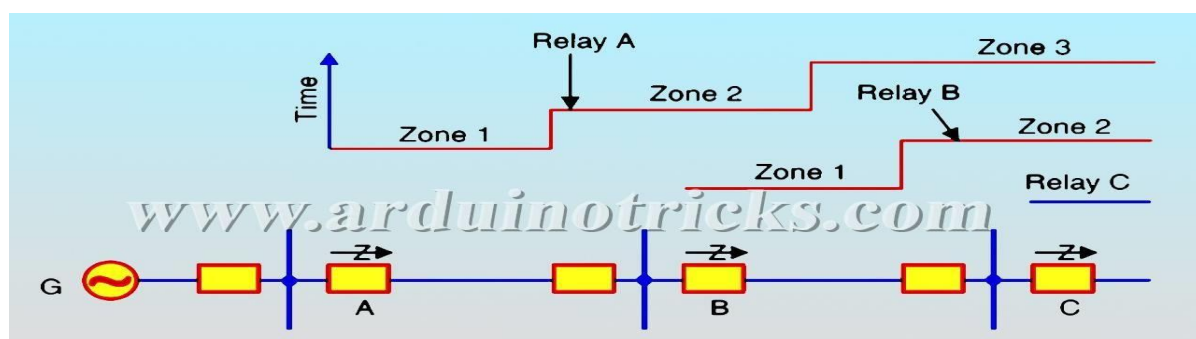

- Above figure shows a simple system consisting of lines in series such that power can flow only from left to right .
- The relays at A,B and C are set to operate for impedance less than Z_1 , Z_2 and Z_3 respectively .
- Suppose a fault occurs between substations B and C the fault impedance at power station and s/s A and B will be Z_1 and Z respectively.
- It is clear that for the portion shown only relay at B will operate.
- Similarly if a fault occurs within section AB ,then only relay at A will operate.

Differential pilot wire protection (Merz-price Voltage Balance system):

Schematic arrangement:

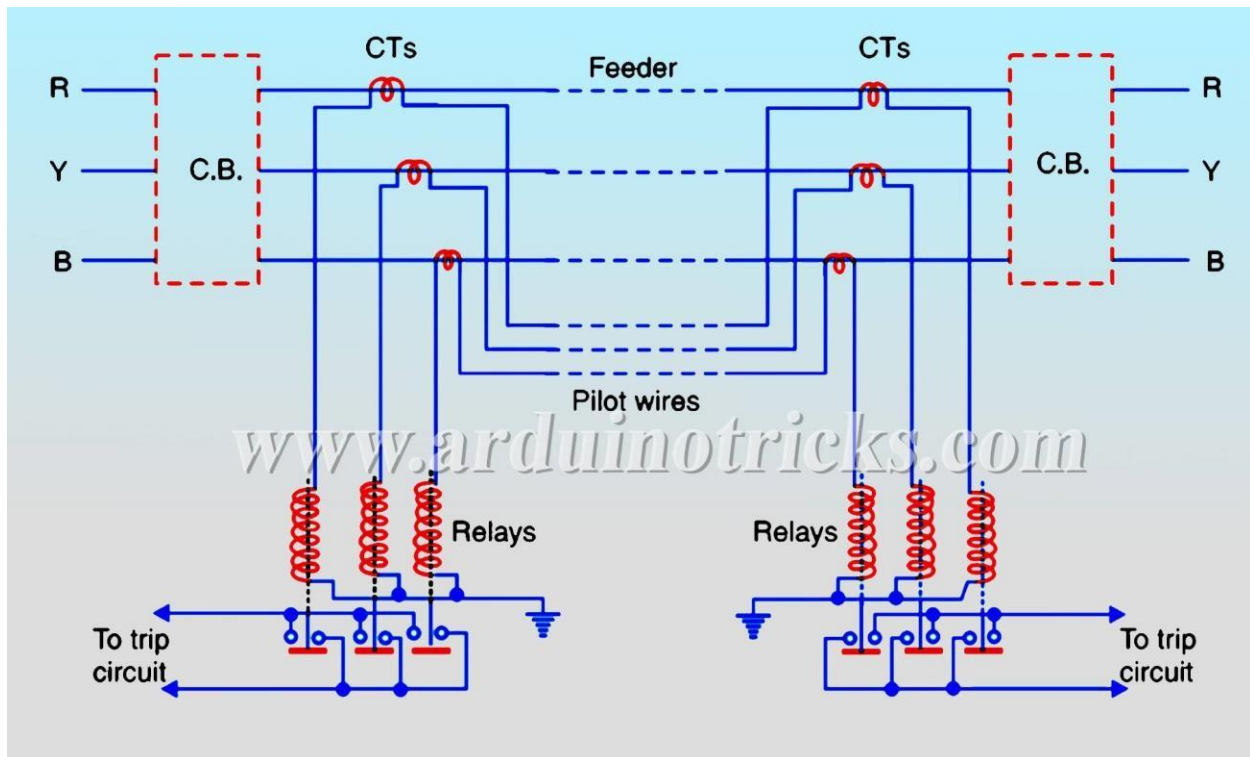

- Above shows the single line diagram of Merz-price voltage balance system for protection of a 3- ϕ line.
- Identical current transformers are placed in each phase at both ends of the line.
- The pairs of CTs in each line is connected in series with a relay.

Operation:

- Under normal condition, current entering the line at one-end is equal to that leaving it at the other end.
- Therefore equal and opposite voltages are induced in the secondaries of the CTs at the two ends of the line.
- The result is that no-current flows through the relays.

- Suppose a fault occurs at point F on the line , this will cause a greater current to flow through CT₁ then through CT₂.
- Finally, their secondary voltages becomes unequal and circulating current flows through the pilot wires and relays.
- The circuit breakers at both ends of the line will trip out and the faulty line will be isolated.

Explain protection of feeder by over current and earth fault relay:

Schematic arrangement:

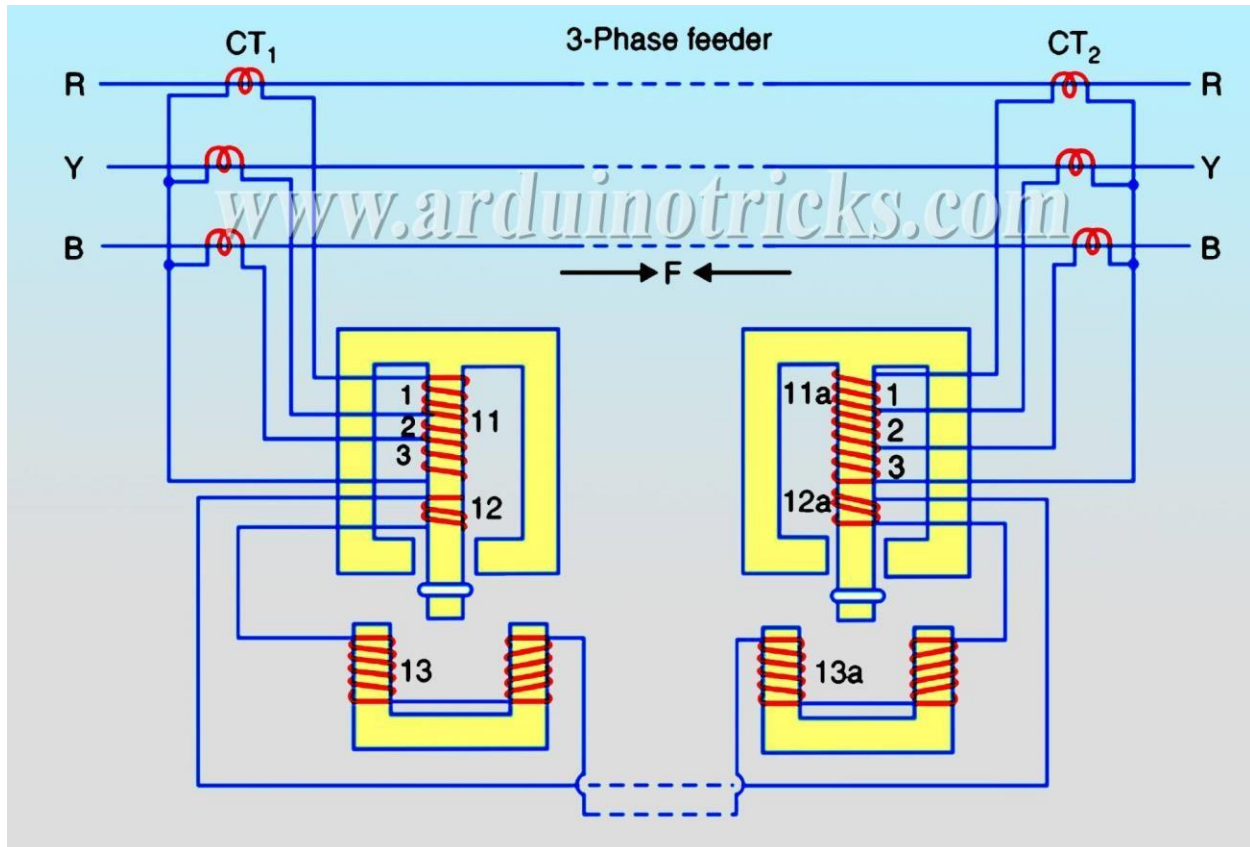

- The relays used in the scheme are essentially over current induction type relay.
- Each relay has two electromagnetic elements .
- The upper element carries a winding (11 or 11a) which is energised as a summation transformer from the secondaries of the line CTs connected in the phases of the line to be protected.
- The upper element also carries a secondary winding (12 or 12a) which is connected in series with the operating winding (13,13a) on the lower magnet.
- The secondary windings 12,12a and operating windings 13,13a are connected in series.

Operation:

- When the feeder is sound, the currents at its two ends are equal so that secondary current on both sides of CTs are equal.

- Finally the currents flowing in the relay primary windings 11 and 11a will be equal and they induce equal voltages in secondary windings 12 and 12a.
- Since these windings are connected in opposition ,no current flows in them or in the operating windings 13 or 13a.
- When fault occurs on the protected line,unequal currents will flow,as a result the torque will developed to rotate the disc.
- Hence the circuit breaker should open the faulty section.

SHORT QUESTIONS WITH ANSWERS AND LONG QUESTIONS WITH HINTS:

What is differential protection ?

ANS : The differential protection is that which responds to the phasor difference between two or more electrical quantities.

Which type of relays are used in Merz-price protection system for alternator ?

ANS: The relays used in Merz-price protection system of alternator are instantaneous electromagnetic type .

In which type of transformer Buchholz relays are used ?

ANS: Buchholz relay are used on oil immersed power transformers pf rating above 750 kva.

Q-4 Buchholz relay is a -----

ANS: Buchholz relay is a gas actuated relay.

Q-5 Write down the position of Buchholz relay?

ANS: Buchholz relay is connected in the pipe connecting main tank of transformer and conservator.

Q-6 A transmission line is protected by

ANS: A transmission line is protected by distance protection and inrush current protection.

LONG QUESTIONS:

Q-1 Write short notes on differential protection of alternator .[2016(s),2017(s),2018(w)]

Q-2 Explain about protection scheme of power system ? [2018(W)]

Explain earth-fault protection for transformer .[2015(S)]

Explain with neat diagram the working of a Buchholz relay.[2014(S), 2015(S)]

END

PROTECTION AGAINST OVER VOLTAGE AND LIGHTNING:

Voltage surge: A sudden rise in voltage for a very short duration on the power system is known as a voltage surge or transient voltage.

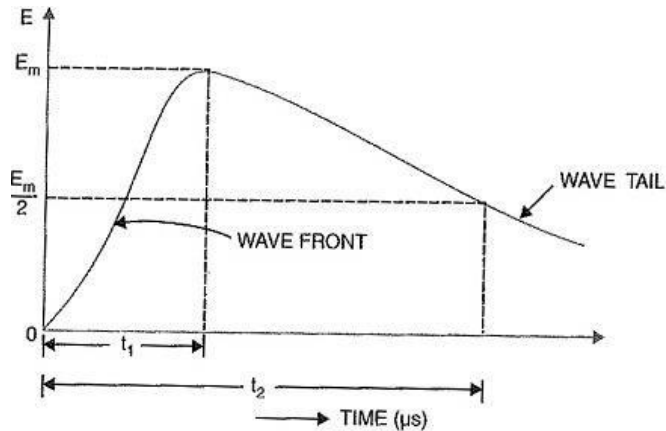

Above figure shows the wave form of a typical lightning surge.

Causes of over voltages: The causes of over voltages on a power system divided into two main types e.g

Internal causes:

- Switching surges.
- Insulation failure.
- Arcing ground.
- Resonance.

External causes

- i.e lightning.

Internal causes of over voltages:

Switching surges: The over voltages produced on the power system due to switching operations are known as switching surges.

Insulation failure: The over voltages produced on the power system due to insulation failure between line earth.

Arcing ground: The phenomenon of arc taking place in line to ground fault of a 3- ϕ system with consequent production of transients is known as arcing ground.

Resonance: The over voltages produced on the power system due to resonance condition.

External causes of over voltage (lightning): An electric discharge between cloud and earth between clouds or between the charge centers of the same cloud is known as lightning.

Mechanism of lightning discharges:

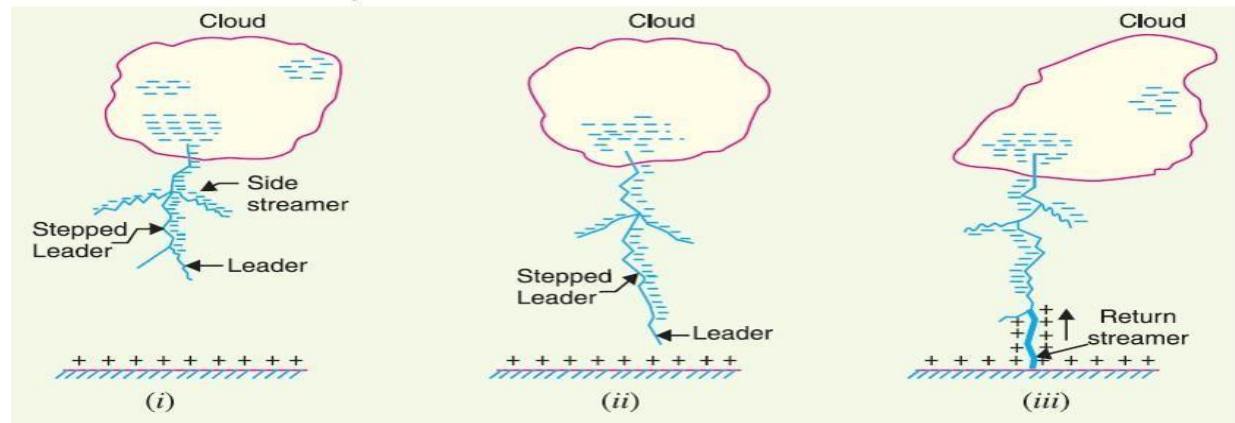

- In atmosphere the drops of water accumulate to form clouds.
- Cloud may posses either a positive or negative depending upon the charge of drops of water they contain.
- When a charged cloud passes over the earth ,it induces equal and opposite charge on earth below it.
- As soon as the air near the cloud breaks down , a streamer called leader streamer or pilot streamer starts flowing from the cloud towards the earth as shown in above figure.
- After that a return streamer starts flowing from earth to cloud.
- At that moment the return streamer and leader streamer collide with each other .
- This phenomenon causes a sudden spark which we called lightning.

Types of lightning strokes: There are two mains ways in which a lightning may strike the power system (e.g over head lines ,towers,substations etc) namely:

- Direct stroke
- Indirect stroke

Direct stroke:

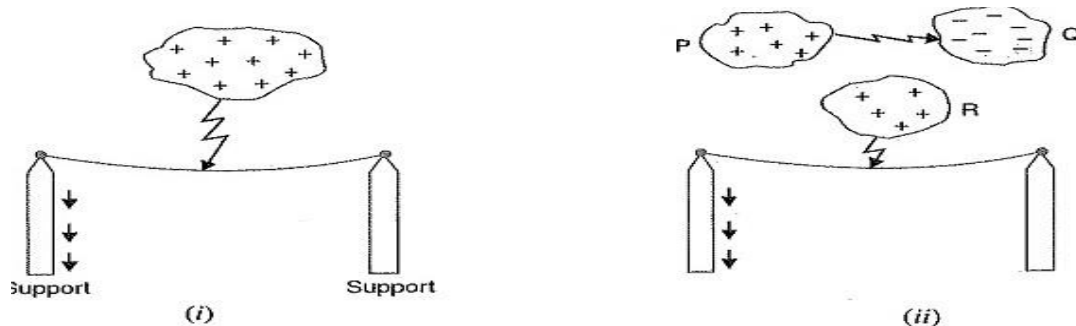

- In the direct stroke ,the lightning discharge (i.e current path) is directly from the cloud to the subject equipment e.g an over head lines.
- Direct strokes are two stroke A and stroke B which are shown in fig above.
- Direct strokes are very rare.
- Stroke A will always occurs on tall objects and hence protection can be provided against it.
- Stroke B completely ignores the height of the object and can even strike the ground and hence protection against stroke B cannot be provided.

Indirect stroke:

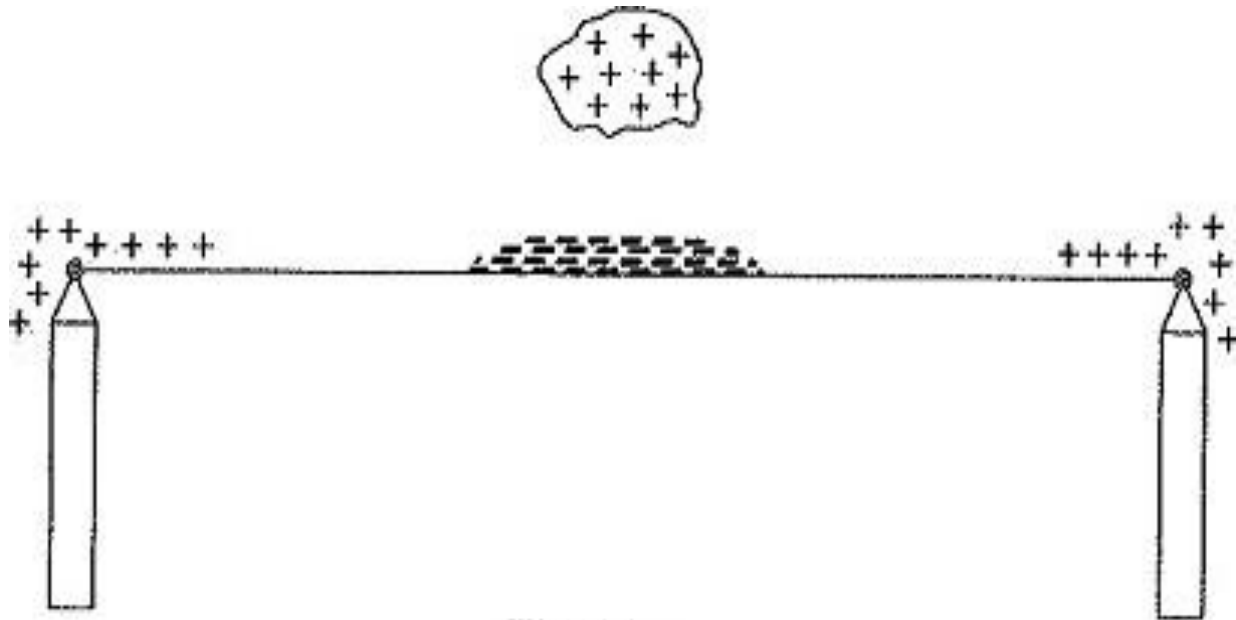

- In the indirect stroke the lightning discharge (i.e current path) is not directly from the cloud the subject equipment.
- The indirect stroke is shown in fig above.
- The majority of surges in a transmission line are caused by indirect lightning strokes ,which moves as travelling waves in the powe lines.

Harmful effects of lightning:

- Cracks the insulators and poles.
- Damage the windings of transformers and generators.
- The insulation propoties of oil decreases in the power equipment ,resulting in the production of arc.
- The production of the arc will set-up very disturbing oscillations in the line.

Lightning arresters: A lightning arrester or a surge diverter is a protective device which conducts the high voltage surge on the power system to the ground.

Circuit diagram:

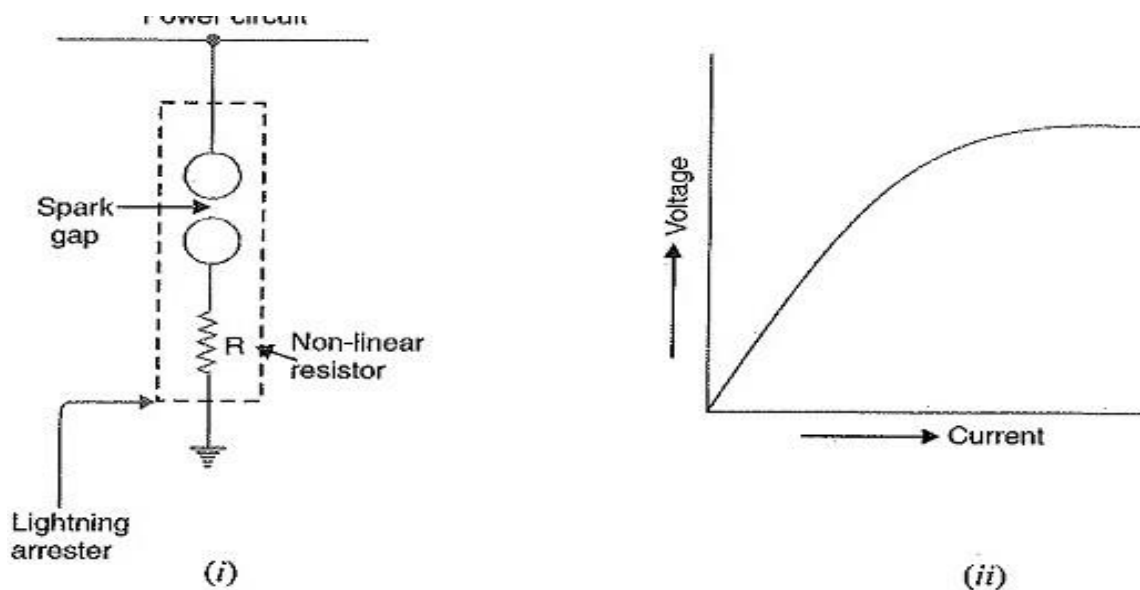

- Above figure shows the basic form of a surge diverter.
- It consists of a spark gap in series with a non-linear resistor.
- One end of the diverter is connected to the terminal of the equipment to be protected and the other end is effectively grounded.
- The length of the gap is so set that normal line voltage is not enough to cause an arc across the gap but a dangerously high voltage will break down the air insulation and form an arc.

Operation:

- Under normal operation , the lightning arrester is off the line i.e it conduct no current to earth or the gap is non-conducting.
- On the occurrence of over voltage , the air insulation across the gap breaks down and an arc is formed ,providing a low resistance path for the surge to the ground.
- In this way , the excess charge on the line due to the surge is harmlessly conducted through the arrester to the ground instead of being sent back over the line.

Types of lightning arresters: These are the following types of lightning arresters:

- Rod-gap lightning arrester.
- Horn-gap arrester.
- Valve type arrester.

Rod-gap lightning arrester:

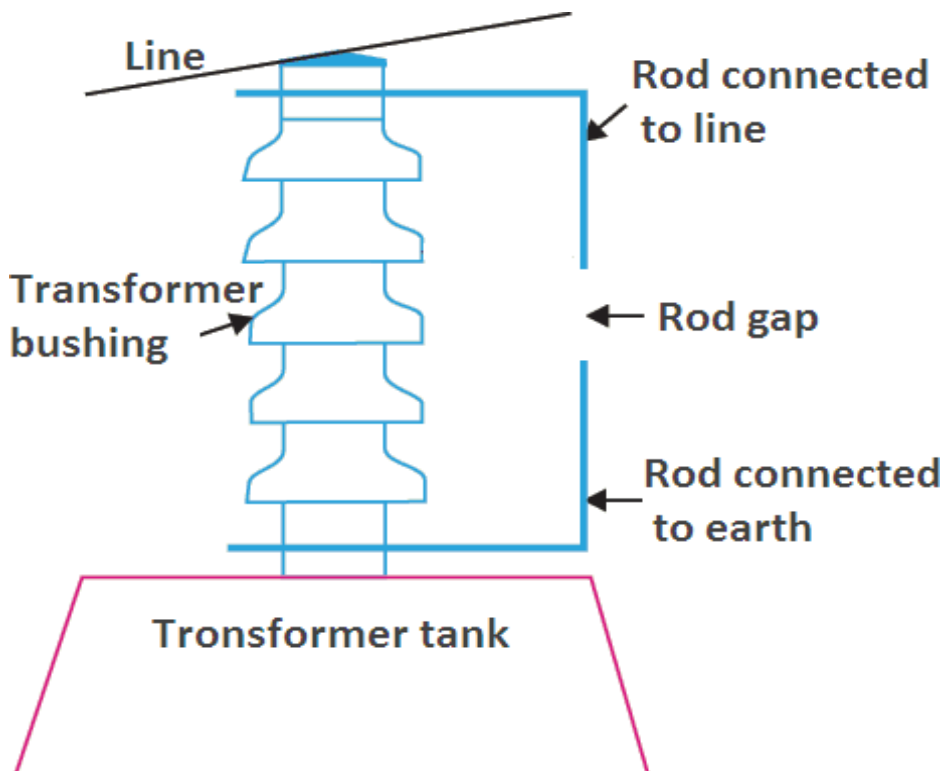

Construction:

- It consists of two 1.5 cm rods which are bent at right angles with a gap in between two.
- One rod of lightning arrester is connected to the line circuit.
- Other rod is connected to earth.
- The distance between gap and insulator (i.e distance P) must not be less than one third of the gap length.

Operation:

- Under normal operating conditions , the gap remains non-conducting .
- On the occurrence of a high voltage surge on the line due to the surge is harmlessly conducted to earth.

Limitations:

- After the surge is over ,the arc in the gap is maintained by the normal supply voltage leading to a short circuit on the system.
- The rod may melt or get damaged due to excessive heat produced by the arc.
- The climatic conditions (e.g rain,humidity,temperature etc.) affect the performance of rod gap arrester.
- The polarity of the surge also affects the performance of this arrester.

Horn gap lightning arrester:

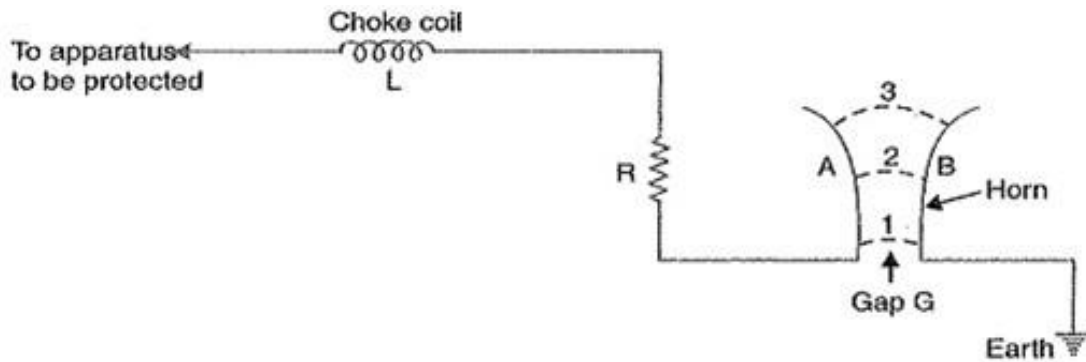

Construction :

- It consists of two horn shaped metal rods A and B separated by a small air gap.
- The horns are so constructed that distance between them gradually increases towards the top as shown.
- The horns are mounted on porcelain insulators.
- One end of horn is connected to the line through a resistance R and choke L while the other end is effectively grounded.

Operation:

- Under normal conditions , the gap is non-conducting i.e normal supply voltage is insufficient to initiate the arc between the gap.
- On the occurrence of an over voltage,spark-over takes place across the small gap G .
- The heated air around the arc and the magnetic effect of the arc cause the arc to travel up gap.
- The arc moves progressively into positions 1,2 and 3 at some position of the arc (perhaps position 3) the distance may be too great for the voltage to maintain the arc.
- Finally the arc is extinguished.
- The excess charge on the line is thus conducted through the arrester to the ground.

Advantages:

- The arc is self clearing. Therefore this type of arrester doesnot cause short-circuiting of the system after the surge is over as in the case of horn-gap.
- Series resistance helps in limiting the follow current to a small value.

Limitations:

- The bridging of gap by some external agency (e.g birds) can render the device useless.
- The setting of horn-gap likely to change due to corrosion or pitting.This adversely affects the performance of the arrester.
- The time of operation is comparatively long say about 3 seconds.

Valve Type Arrester:

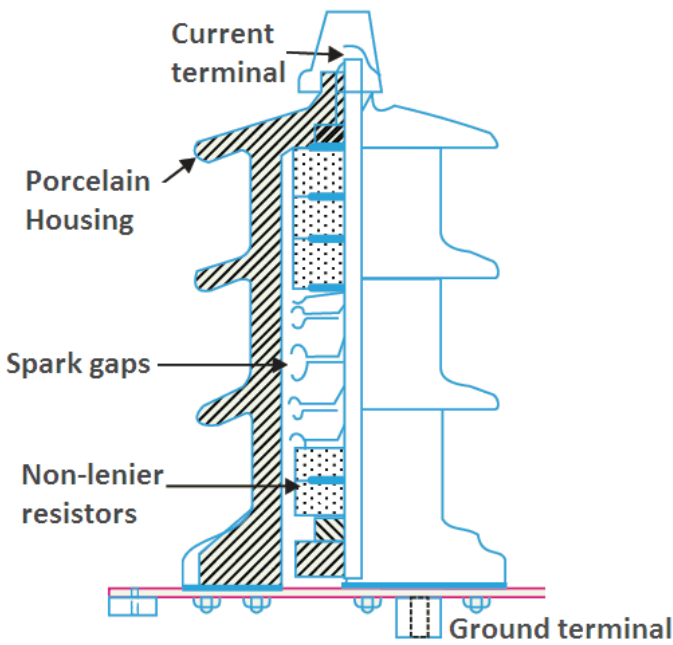

Valve type arrester

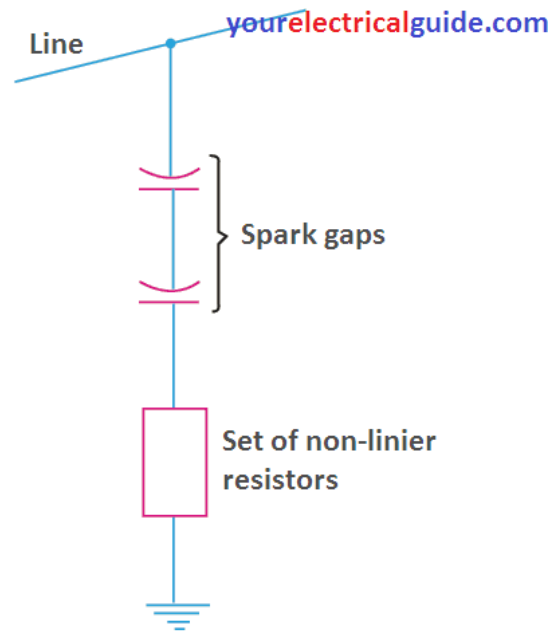

Equivalent Circuit

Construction:

- It consists of two assemblies (i) series spark gaps and (ii) non-linear resistor discs (made of material such as thyrite or metrosil) in series.
- The non-linear elements are connected in series with the spark gaps.
- Both the above assemblies are accommodated in tight porcelain container.

Working:

- Under normal conditions the system voltages is insufficient to cause the break down of air gap assembly.
- On the occurrence of an over voltage the break down of series spark gap takes place and the surge current is conducted to earth through the non-linear resistors.
- Since the magnitude of surge current is very large , the non-linear elements will offer a very low resistance to the passage of surge.
- The result is that the surge will rapidly go to earth instead of being sent back over the line.

Advantages:

- They provide very effective protection against surges.
- They operate very rapidly taking less than a second.
- The impulsive ratio is practically unity.

Limitations:

- They may fail to check the surges of very steep wave front from reaching the terminal apparatus. This calls for additional steps to check steep-fronted waves.
- Their performance is adversely affected by the entry of moisture into the enclosure. This necessitates effective sealing of enclosure at all times.

Surge absorber:

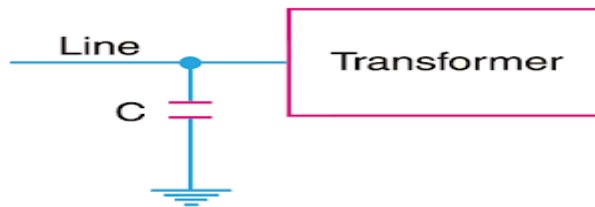

A surge absorber is a protective device which reduces the steepness of wave front of a surge by absorbing surge energy.

The surge diverter diverts the surge to earth but the surge absorber absorbs the surge energy .

A few cases of surge absorption are discussed below :

As shown in above diagram a condenser is connected across the line and earth can acts as a surge absorber .Since the reactance of a condenser is inversely proportional to frequency , it will be low at high frequency and high at low frequency .Since the surges are of high frequency ,the capacitors acts as a short circuit and passes them directly to earth. However for power frequency , the reactance of the capacitor is very high and practically no current flow to the ground.

- Another type of surge absorber diagram shown in fig below:

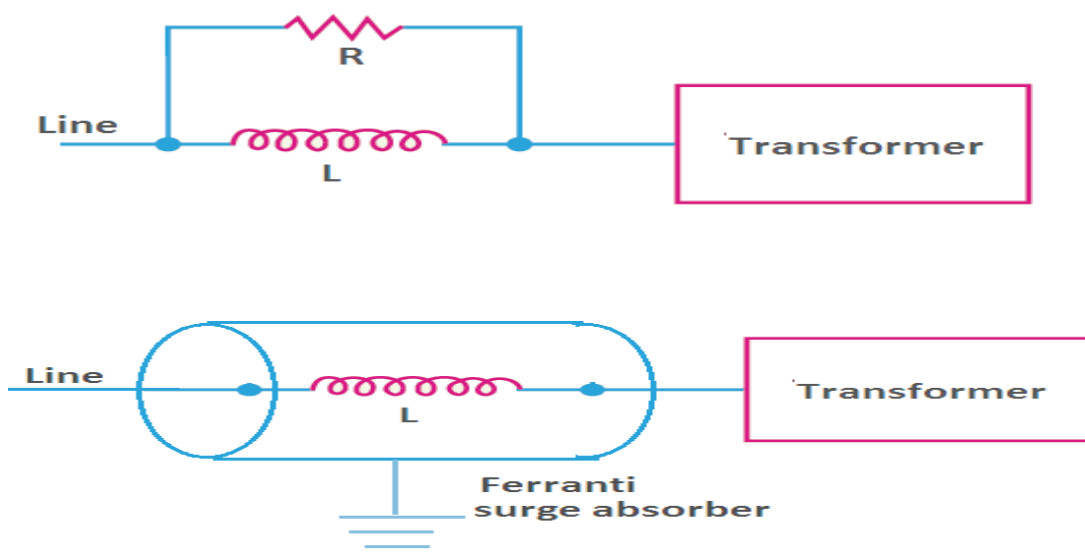

Short questions with answer and long questions with hints:

What is lightning arrester ? [2011(s)]

ANS: A lightning arrester or a surge diverter is a protective device which conducts the high voltage surge on the power system to the ground.

Define voltage surge .

ANS: A sudden rise in voltage for a very short duration on the power system is known as a voltage surge or transient voltage.

What is surge absorber ?

ANS: A surge absorber is a protective device which reduces the steepness of wave front of a surge by absorbing surge energy.

What is arcing ground ? [2015(S)]

ANS: The phenomenon of intermittent arc taking place in line to ground fault of a 3- ϕ system with consequent production of transients is known as arcing ground.

State harmful effect of lightning ? [2016(S),2017(S)]

ANS:

- Cracks the insulators and poles.
- Damage the windings of transformers and generators.
- The insulation properties of oil decreases in the power equipment ,resulting in the production of arc.
- The production of the arc will set-up very disturbing oscillations in the line.

What are the causes of over voltage ?[2016(S),2017(S),2018(S)]

ANS:

Internal causes:

- Switching surges.
- Insulation failure.
- Arcing ground.
- Resonance.

External causes

i.e lightning

Long questions:

Q-1 What is Horn-gap lightning arrester? Explain how it works.[2012(S),2011(S),2018(S)]

Q-2 Explain valve type arrester .[2015(S),2016(S),2017(S),2019(S)]

Explain surge Absorber.[2016(S),2017(S)]

Explain harmful effects of lightning.[2018(S)]

Write short notes on Rod-Gap lightning arrester.[2018(S),2018(W)]

What is lightning ? Describe mechanisim of lightning discharge.[2019(S)]

END

STATIC RELAY:

Definition of static relay: A relay using combination of both static and electromagnetic units is also called as static relay.

Advantages of static relay:

- Low power consumption.
- Quick response.
- Long life.
- Shock proof.
- Fewer problems of maintenance.
- High reliability and a high degree of accuracy.
- A static relay can perform several functions such as protections , monitoring, data acquisition, measurement, memory indication, data communication etc.
- Static relays can be designed for repeated operations.
- The risk of unwanted tripping is less with static relays.
- Static relays are very compact.
- The characteristics of static relays are accurate and superior.

Instantaneous overcurrent relay:

- There is no time difference between the occurrence of fault and the operations of the relay.
- The relay operates when the current in the relay coil exceeds the pick-up value.
- The operating time of this type of relay is less than 0.1 sec
- An instantaneous overcurrent relay is one in which no intentional time delay is provided for operation.
- In such a relay the relay contacts close immediately after the current in the relay coil exceeds for which it is set.
- Although there will be a short time interval between the instant of pick-up and the closing of the relay contacts, no intentional time delay is provided.

Principle of IDMT relay:

- Inverse definite minimum time relays.
- Such a relay is one in which operating time is approximately inversely proportional to fault current near pick-up value and becomes substantially constant slightly above the pick-up value of the relay as shown in below figure.
- This is achieved by using a core of the electromagnet which gets saturated for currents than the pick-up currents.

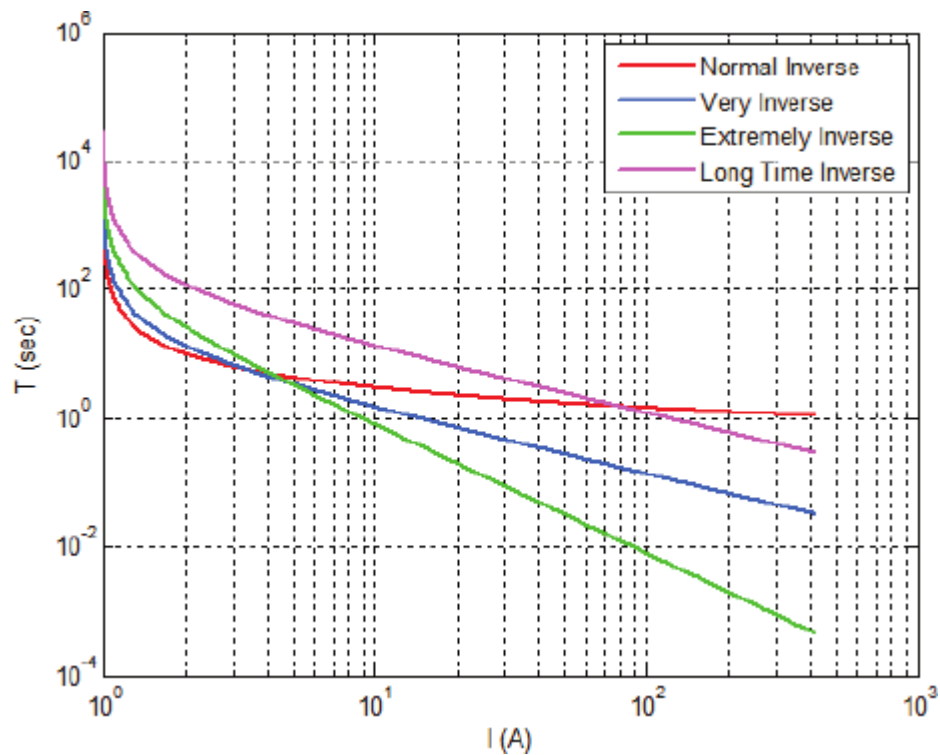

Short questions with answer:

Q-1 What is static relay ?

ANS: A relay using combination of both static and electromagnetic units is also called as static relay.

Q-2 Write advantages of static relays.

ANS: Long life, efficiency high, low power loss, quick response, it has shock proof.

Long questions:

Write short notes on IDMT relay. [2014(S),2018(W)]

Write advantages of static relays. [2015(S),2016(S),2017(S)]

END